

HANGAR 9

Spitfire 60 ARF

ASSEMBLY MANUAL



Specifications

Wingspan.....	65.25 in (1657mm)	Length.....	55.5 in (1410mm)
Wing Area	729.5 sq in (47.06 sq dm)	Weight.....	8.0–9.0 lb (3.6kg–4.0kg)

Table of Contents

Contents of Kit	3
Radio and Power Systems Requirements	3
UltraCote® Covering Colors	4
Field Equipment Required	4
Optional Field Equipment	4
Required Tools and Adhesives	4
Limited Warranty Period	5
Limited Warranty & Limits of Liability	5
Safety Precautions	5
Questions, Assistance, and Repairs	5
Questions or Assistance	5
Inspection or Repairs	6
Warranty Inspection and Repairs	6
Non-Warranty Repairs	6
Safety, Precautions, and Warnings	7
Before Starting Assembly	7
Using the Manual	7
Section 1: Aileron Installation	8
Section 2: Joining the Wing Panels	14
Section 3: Retract Installation	18
Section 4: Flap Installation	21
Section 5: Engine Installation	24
Section 6: Cowling Installation	27
Section 7: Rudder Installation	29
Section 8: Stabilizer Installation	32
Section 9: Final Assembly	37
Adjusting the Engine	40
Control Throws	40
Recommended Center of Gravity (CG)	41
Pre-Flight	41
Range Test Your Radio	41
2006 Official AMA National Model Aircraft Safety Code	42

Contents of Kit

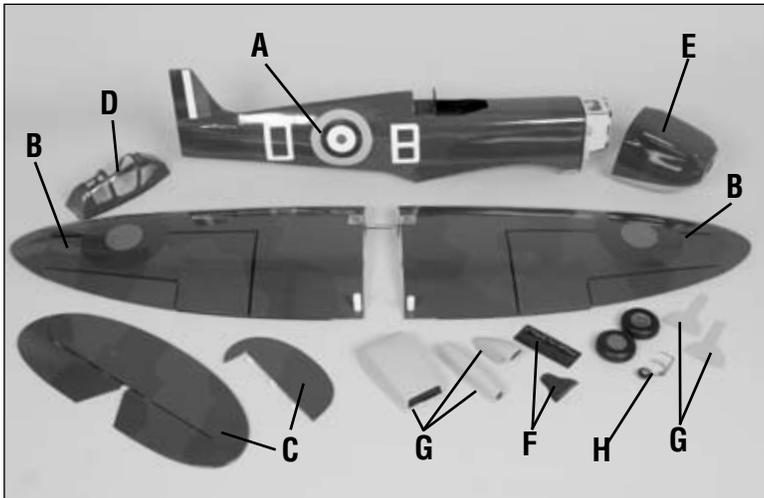

Replacement Parts

A. HAN4251	Fuselage
B. HAN4252	Wing Set, Ailerons, Joiners and Retracts
C. HAN4253	Tail Set
D. HAN4254	Canopy w/Painted Frame
E. HAN4256	Painted Fiberglass Cowl
F. HAN4261	Cockpit Detail Set and Exhaust Set
G. HAN4257	Molded Wheel Well, Strut Covers and Radiators
H. HAN4258	Tail Wheel Assembly

Items not shown

HAN4259	Decal Set
HAN4260	Pushrod Set
HAN4262	Retracts

Radio and Power Systems Requirements

- 5- to 6-channel radio system (minimum) w/receiver
- 537 Standard Servo (JRPS537) (5) or equivalent for rudder (1), elevator (1), ailerons (2), throttle (1)
(Plus 1 servo required when using the flap option)
(Plus 1 JRPS791 or equivalent for retracts)
(4 required when building the electric version)
- 12" Servo Lead Extension (JRPA098) (2)
- 6" Y-Harness (JSP98020)

Recommended JR® or JR SPORT™ Systems

- XP9303
- XP7202
- XP6102
- XS600



JR XP9303



JR XP6102



JR XP7202

Recommended Power Systems

- .60-.61 2-stroke
- .91-1.00 4-stroke
- Power 60 Brushless Outrunner



Evolution .61NT
EVOE0610



Saito 1.00 AAC
SAIE100



E-Flite™ Power 60
Brushless Outrunner
Motor, 400KV
EFLM4060A

UltraCote® Covering Colors

Cocoa HANU876
Light Grey HANU882

Olive Drab HANU904

Field Equipment Required

- Propeller
- Long Reach Glow Plug Wrench (HAN2510)
- 2-Cycle Sport Plug (HAN3001)
- 2-Cycle Super Plug (HAN3006)
- 4-Cycle Super Plug (HAN3011)
- Metered Glow Driver w/Ni-Cd & Charger (HAN7101)
- Fuel
- Manual Fuel Pump (HAN118)

Optional Field Equipment

- 12V 7Ah Sealed Battery (HAN102)
- PowerPro™ 12V Starter (HAN161)

Required Tools and Adhesives

Tools

- Canopy scissors
- Square
- Foam: 1/4" (6mm)
- Side cutters
- Phillips screwdriver (small)
- Ruler
- Hex wrench: 9/64", 3/16"
- Drill bit: 1/16" (1.5mm), 5/64" (2mm), 3/32" (2.5mm), 1/8" (3mm), 9/64" (3.5mm), 5/32" (4mm), 1/4" (6mm)
- Drill
- Flat blade screwdriver
- Hobby knife
- Phillips screwdriver (large)
- Pliers
- Sandpaper
- Socket wrench: 11/32"

Adhesives

- 6-minute epoxy
- Thin CA (cyanoacrylate) glue
- CA remover/debonder
- Zap-A-Dap-A-Goo
- Canopy glue (Formula 560)
- 30-minute epoxy
- Medium CA (cyanoacrylate) glue
- Pacer Z-42 Threadlock
- Hinge glue
- Masking tape (3M blue recommended)

Other Required Items

- Epoxy brushes
- File
- Mixing sticks for epoxy
- Petroleum jelly
- Sanding bar
- String
- Wax paper
- Felt-tipped pen or pencil
- Measuring device (e.g. ruler, tape measure)
- Paper towels
- Rubbing alcohol
- Sandpaper (medium)
- T-pins
- Rotary tool w/sanding drums

Limited Warranty Period

Horizon Hobby, Inc. guarantees this product to be free from defects in both material and workmanship at the date of purchase.

Limited Warranty & Limits of Liability

Pursuant to this Limited Warranty, Horizon Hobby, Inc. will, at its option, (i) repair or (ii) replace, any product determined by Horizon Hobby, Inc. to be defective. In the event of a defect, these are your exclusive remedies.

This warranty does not cover cosmetic damage or damage due to acts of God, accident, misuse, abuse, negligence, commercial use, or modification of or to any part of the product. This warranty does not cover damage due to improper installation, operation, maintenance, or attempted repair by anyone other than an authorized Horizon Hobby, Inc. service center. This warranty is limited to the original purchaser and is not transferable. In no case shall Horizon Hobby's liability exceed the original cost of the purchased product and will not cover consequential, incidental or collateral damage. Horizon Hobby, Inc. reserves the right to inspect any and all equipment involved in a warranty claim. Repair or replacement decisions are at the sole discretion of Horizon Hobby, Inc. Further, Horizon Hobby reserves the right to change or modify this warranty without notice.

REPAIR OR REPLACEMENT AS PROVIDED UNDER THIS WARRANTY IS THE EXCLUSIVE REMEDY OF THE CONSUMER. HORIZON HOBBY, INC. SHALL NOT BE LIABLE FOR ANY INCIDENTAL OR CONSEQUENTIAL DAMAGES.

As Horizon Hobby, Inc. has no control over use, setup, final assembly, modification or misuse, no liability shall be assumed nor accepted for any resulting damage or injury. By the act of use, setup or assembly, the user accepts all resulting liability.

If you as the purchaser or user are not prepared to accept the liability associated with the use of this product, you are advised to return this product immediately in new and unused condition to the place of purchase.

Safety Precautions

This is a sophisticated hobby product and not a toy. It must be operated with caution and common sense and requires some basic mechanical ability. Failure to operate this product in a safe and responsible manner could result in injury or damage to the product or other property. This product is not intended for use by children without direct adult supervision. The product manual contains instructions for safety, operation and maintenance. It is essential to read and follow all the instructions and warnings in the manual, prior to assembly, setup or use, in order to operate correctly and avoid damage or injury.

Questions, Assistance, and Repairs

Your local hobby store and/or place of purchase cannot provide warranty support or repair. Once assembly, setup or use of the product has been started, you must contact Horizon Hobby, Inc. directly. This will enable Horizon to better answer your questions and service you in the event that you may need any assistance.

Questions or Assistance

For questions or assistance, please direct your email to productsupport@horizonhobby.com, or call 877.504.0233 toll free to speak to a service technician.

Inspection or Repairs

If your product needs to be inspected or repaired, please call for a Return Merchandise Authorization (RMA). Pack the product securely using a shipping carton. Please note that original boxes may be included, but are not designed to withstand the rigors of shipping without additional protection. Ship via a carrier that provides tracking and insurance for lost or damaged parcels, as Horizon Hobby, Inc. is not responsible for merchandise until it arrives and is accepted at our facility. Include your complete name, address, phone number where you can be reached during business days, RMA number, and a brief summary of the problem. Be sure your name, address, and RMA number are clearly written on the shipping carton.

Warranty Inspection and Repairs

To receive warranty service, you must include your original sales receipt verifying the proof-of-purchase date. Providing warranty conditions have been met, your product will be repaired or replaced free of charge. Repair or replacement decisions are at the sole discretion of Horizon Hobby.

Non-Warranty Repairs

Should your repair not be covered by warranty and the expense exceeds 50% of the retail purchase cost, you will be provided with an estimate advising you of your options. You will be billed for any return freight for non-warranty repairs. Please advise us of your preferred method of payment. Horizon Hobby accepts money orders and cashiers checks, as well as Visa, MasterCard, American Express, and Discover cards. If you choose to pay by credit card, please include your credit card number and expiration date. Any repair left unpaid or unclaimed after 90 days will be considered abandoned and will be disposed of accordingly.

Electronics and engines requiring inspection or repair should be shipped to the following address (freight prepaid):

Horizon Service Center
4105 Fieldstone Road
Champaign, Illinois 61822

All other products requiring inspection or repair should be shipped to the following address (freight prepaid):

Horizon Product Support
4105 Fieldstone Road
Champaign, Illinois 61822

Safety, Precautions, and Warnings

This model is controlled by a radio signal that is subject to interference from many sources outside your control. This interference can cause momentary loss of control so it is advisable to always keep a safe distance in all directions around your model, as this margin will help to avoid collisions or injury.

- Always operate your model in an open area away from cars, traffic, or people.
- Avoid operating your model in the street where injury or damage can occur.
- Never operate the model out into the street or populated areas for any reason.
- Never operate your model with low transmitter batteries.
- Carefully follow the directions and warnings for this and any optional support equipment (chargers, rechargeable battery packs, etc.) that you use.
- Keep all chemicals, small parts and anything electrical out of the reach of children.
- Moisture causes damage to electronics. Avoid water exposure to all equipment not specifically designed and protected for this purpose.

Before Starting Assembly

Before beginning the assembly of the Spitfire 60, remove each part from its bag for inspection. Closely inspect the fuselage, wing panels, rudder, and stabilizer for damage. If you find any damaged or missing parts, contact the place of purchase.

If you find any wrinkles in the covering, use a heat gun or sealing iron to remove them. Use caution while working around areas where the colors overlap to prevent separating the colors.

Using the Manual



HAN101 – Sealing Iron

**HAN141 – Sealing Iron
Sock**



HAN100 – Heat Gun

HAN150 – Covering Glove

This manual is divided into sections to help make assembly easier to understand, and to provide breaks between each major section. In addition, check boxes have been placed next to each step to keep track of each step completed. Steps with a single box () are performed once, while steps with two boxes () indicate that the step will require repeating, such as for a right or left wing panel, two servos, etc. Remember to take your time and follow the directions.

Section 1: Aileron Installation

Required Parts

- Wing (left and right)
- Nylon clevis (2)
- CA hinges (6)
- #2 x 3/8" sheet metal screw (8)
- 2-56 x 1" machine screw (6)
- Nylon control horn w/backplate (2)
- Threaded pushrod, 6" (150mm) (2)
- Servo mounting block, 3/4" x 3/4" x 3/8" (18mm x 18mm x 10mm) (4)
- Heat shrink tubing
- Aileron (left and right)
- Nylon wire keeper (2)

Required Tools and Adhesives

- Thin CA
- 6-minute epoxy
- Drill
- Low-tack tape
- Phillips screwdriver
- 12" servo extension (2)
- Drill bit: 1/16" (1.5mm), 3/32" (2.5mm)
- T-pins
- Felt-tipped pen
- Side cutters
- Ruler
- Pliers

□ □ Step 1

Remove the aileron from the wing. Place a T-pin in the center of each hinge.

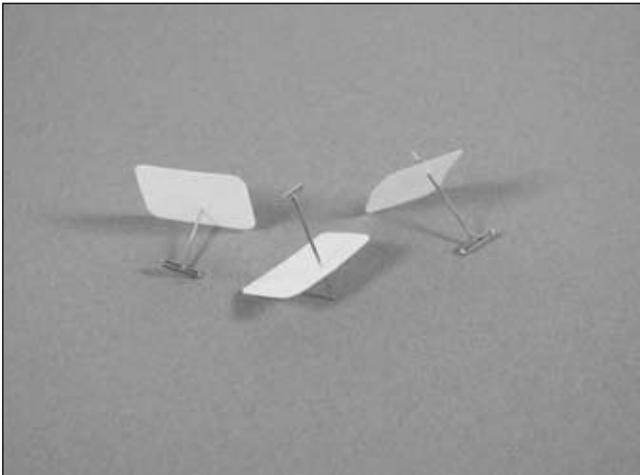

□ □ Step 2

Place the hinges in the precut slots in the aileron. The T-pin will rest against the leading edge of the aileron when installed correctly.



□ □ Step 3

Slide the aileron and wing together. The gap between the leading edge of the aileron and wing should be a maximum of approximately 1/64" (.5mm). Check to make sure the gap at both ends of the aileron are equal and that the aileron can move without rubbing on the wing.



Hint: Start at the tip when installing the aileron to ease the installation.

Note: Do not use CA accelerator during the hinging process. The CA must be allowed to soak into the hinge to provide the best bond. Using accelerator will not provide enough time for this process.

Section 1: Aileron Installation

□ □ Step 4

Remove the T-pins and move the aileron down to provide the best access to the hinge. Apply thin CA to each hinge. Make sure the hinge is fully saturated with CA. Use a paper towel and CA remover/debonder to clean up any excess CA from the wing and/or aileron.



Note: Apply CA to both sides of the hinges.

□ □ Step 5

Firmly grasp the wing and aileron and gently pull on the aileron to ensure the hinges are secure and cannot be pulled apart. Use caution when gripping the wing and aileron to avoid crushing the structure.



□ □ Step 6

Work the aileron up and down several times to work in the hinges and check for proper movement.

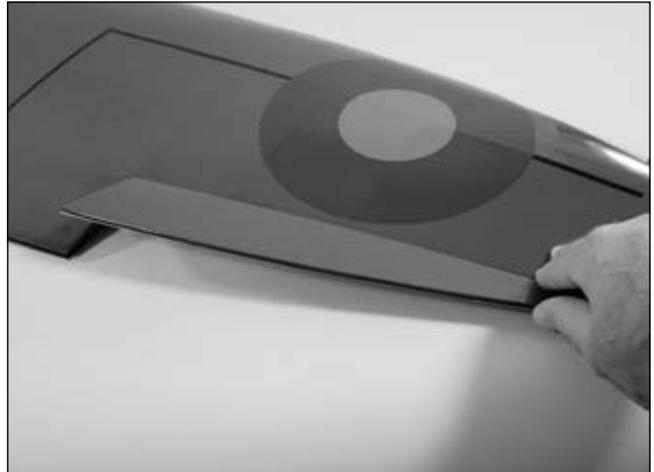

Section 1: Aileron Installation

□ □ Step 7

Remove the aileron hatch from the wing. Remove the covering from the slot for the aileron horn.

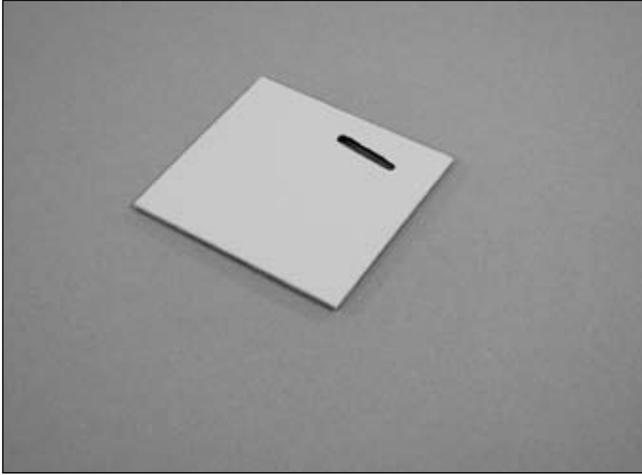

Note: The aileron servo is mounted directly to the hatch.

Hint: Use a ruler as a straight edge to make sure the marks for the servo are parallel to the slot for the servo horn.

□ □ Step 8

Install the recommended servo hardware (grommets and eyelets) supplied with the servo. Temporarily install a long half servo arm (JRPA212) onto the servo and position the servo onto the hatch so the servo arm is centered in the notch. Once satisfied, mark the location for the servo mounting blocks.

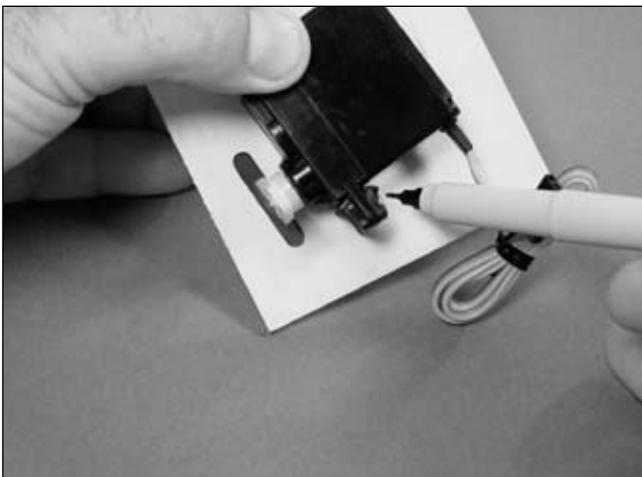

□ □ Step 9

Locate the servo mounting blocks. Use 6-minute epoxy to glue the blocks to the hatch. Let the epoxy fully cure before proceeding to the next step.

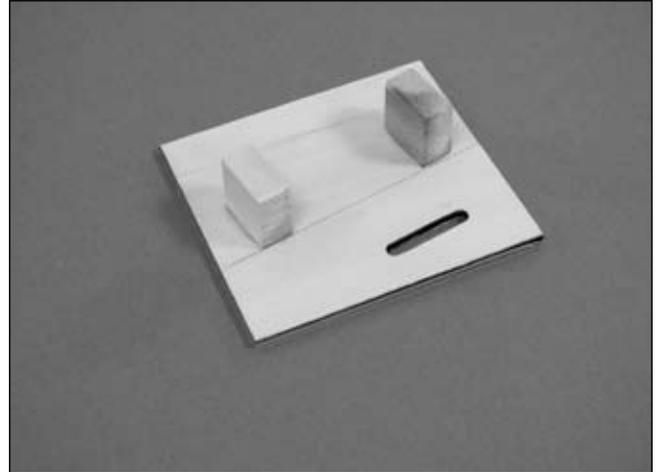

□ □ Step 10

Place the aileron servo between the mounting blocks and use a felt-tipped pen to mark the location of the four servo mounting screws. Note that the servo must not touch the hatch in order to isolate engine vibration.

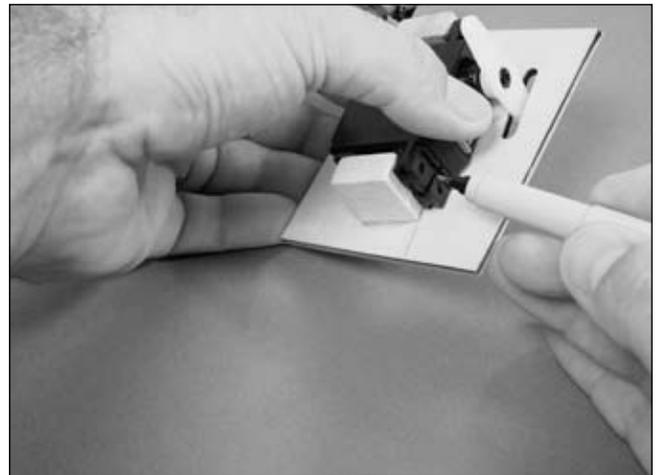

Note: Before mounting the servo, it is suggested to electronically center the servo using the transmitter, then install the servo arm to avoid having to remove the servo and center the arm later. It may be necessary to slightly trim one of the servo mounting blocks to clear the servo wire.

Section 1: Aileron Installation

□ □ Step 11

Remove the servo and use a 1/16" (1.5mm) drill bit to pre-drill the holes for the servo mounting screws marked in the previous step. Use the screws supplied with the servo to mount it to the servo mounting blocks.

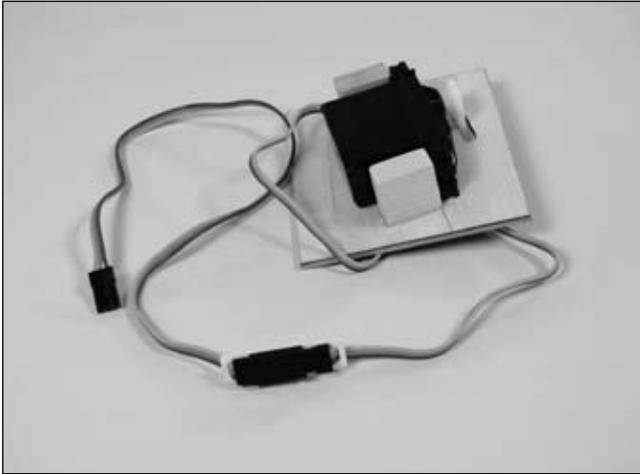

Note: Remove the excess arm that does not extend through the servo hatch so it does not interfere with the operation of the servo.

□ □ Step 12

Connect a 12" Servo Lead Extension (JRPA098) to the servo lead. Secure the connectors by tying them in a knot using dental floss (as shown) or by using a commercially available connector clamp to prevent the servo leads from becoming disconnected.

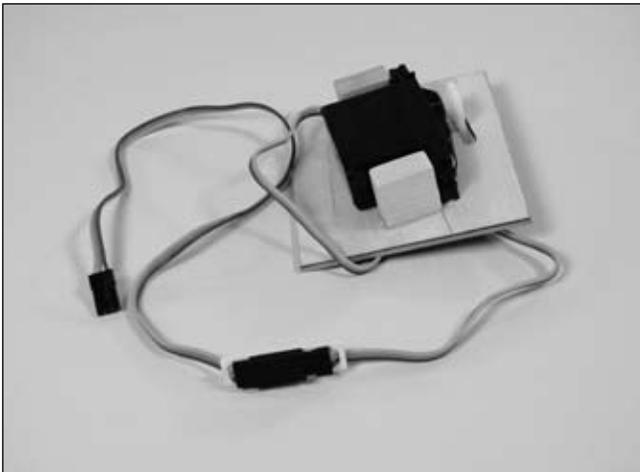

Note: It is always a good idea to secure the servo connector and servo extension together to prevent the wires from becoming unplugged.

□ □ Step 13

Tie the preinstalled string onto the servo extension. Gently pull the extension through the wing using the string. Untie the string when the servo lead has been pulled through. Remove the covering from the opening in the top of the wing and pull the extension through the hole. Use tape to secure the servo lead to the wing to prevent it from falling back into the wing panel.

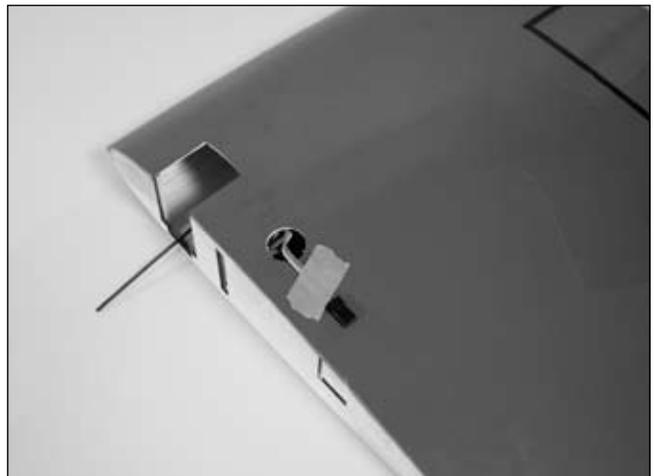
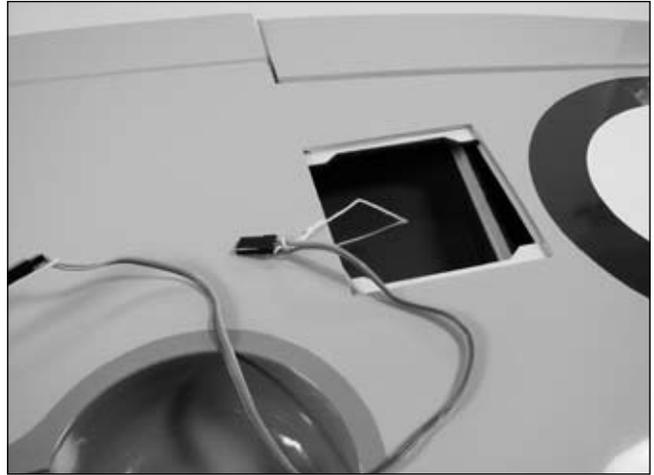

Section 1: Aileron Installation

□ □ Step 14

Place the hatch cover in position in the aileron opening. Measure in 1/8" (3mm) on all four sides of the hatch. Drill four 1/16" (1.5mm) holes at the intersections of the lines as shown. Secure the hatch using four #2 x 3/8" sheet metal screws.

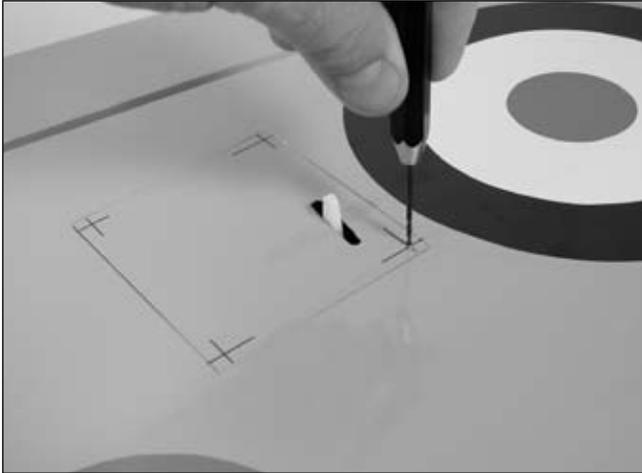

Note: Drill through the servo hatch and the underlying hatch mounts. Use caution not to accidentally drill through the top of the wing.

□ □ Step 15

Remove the back plate from the control horn using side cutters or a sharp hobby knife.

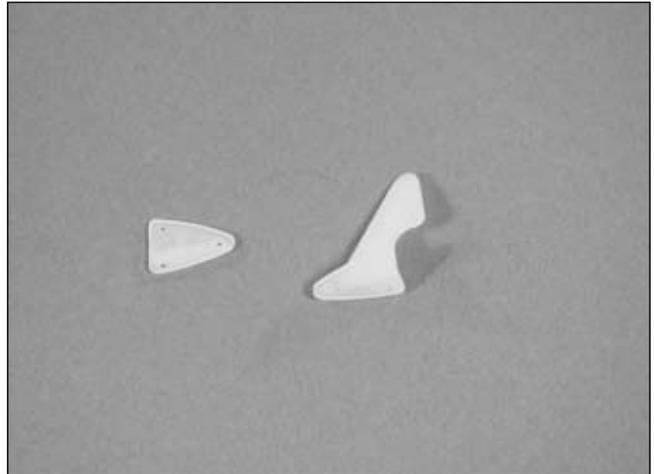

□ □ Step 16

Position the control horn on the aileron so the horn aligns with the aileron servo horn and the aileron hinge line. Mark the position for the mounting holes using a felt-tipped pen.



Hint: Use low-tack tape to secure the aileron in the neutral position when installing the control horn.

Section 1: Aileron Installation

□ □ Step 17

Drill three 3/32" (2.5mm) holes at the locations marked in the previous step.

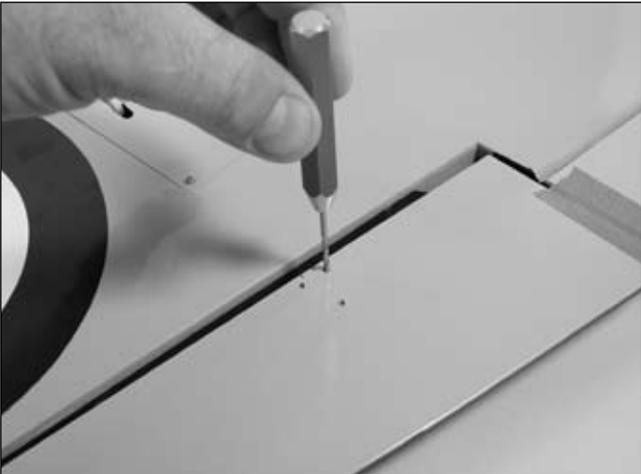

□ □ Step 18

Attach the control horn using three 2-56 x 1" machine screws and the control horn backplate.

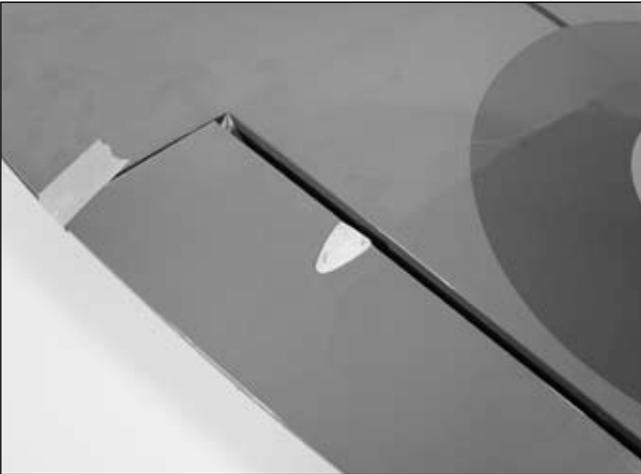

□ □ Step 19

Cut a 1/4" (6mm) piece of the heat shrink tubing and slide it onto a clevis. Thread the clevis onto a 6" wire a minimum of 10 turns.

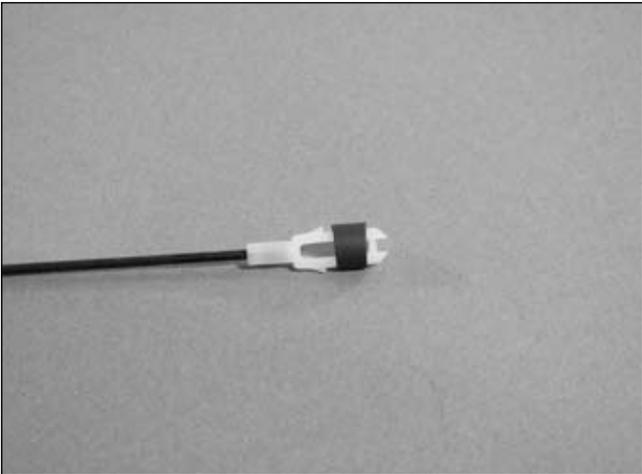

□ □ Step 20

Center the aileron servo electronically using the radio system. Attach the pushrod with clevis to the control horn. Physically place the aileron control surface in neutral. Mark the pushrod where it crosses the holes in the servo arm.

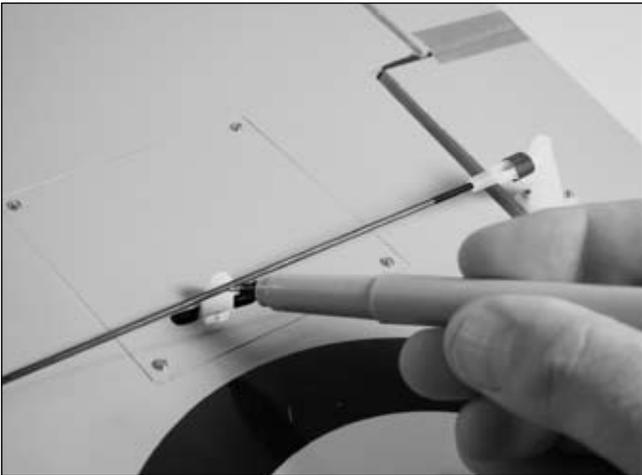

Section 1: Aileron Installation

Step 21

Bend the wire 90 degrees at the mark made in the previous step. Cut the wire 3/8" (10mm) above the bend.

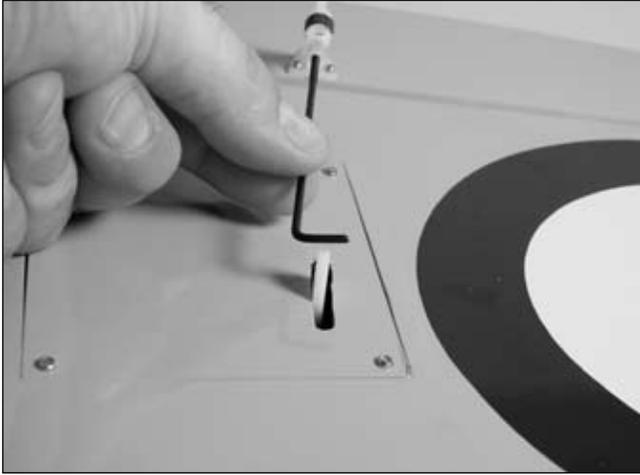

Step 22

Slide the wire through the outer hole in the aileron servo arm. Secure the wire using a nylon wire keeper.

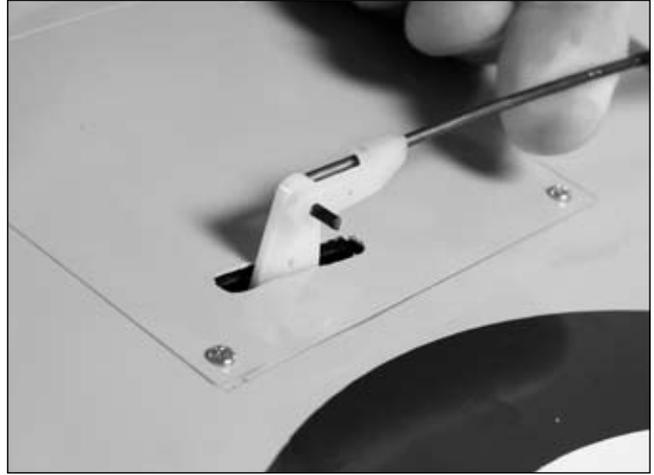

Step 23

Repeat Steps 1 through 22 to install the remaining aileron and aileron servo.

Section 2: Joining the Wing Panels

Required Parts

- Left and right wing panels
- Wing joiner
- Wing dowels (2)

Required Tools and Adhesives

- Masking tape
- Epoxy brush
- Rubbing alcohol
- Drill
- Felt-tipped pen
- 30-minute epoxy
- Mixing stick
- Paper towels
- Drill bit: 1/4" (6mm)
- Hobby knife

Step 1

Test the fit of the wing joiner into one of the wing panels. The joiner should slide into the panel with little resistance. Lightly sand the joiner as necessary to achieve a proper fit. Use a felt-tipped pen to make a reference line on the joiner against the root rib of the wing. Also mark the wing panel and joiner so they can be positioned with the same relationship.

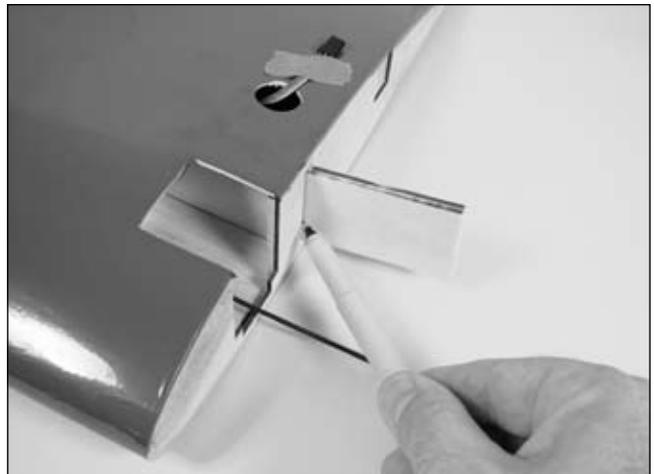

Note: The joiner will be angled toward the top of the wing.

Section 2: Joining the Wing Panels

□ Step 2

Test the fit of the wing joiner into the remaining wing panel. The joiner should again slide into the panel with little resistance up to the line drawn on the joiner. Lightly sand the joiner as necessary to achieve a proper fit.

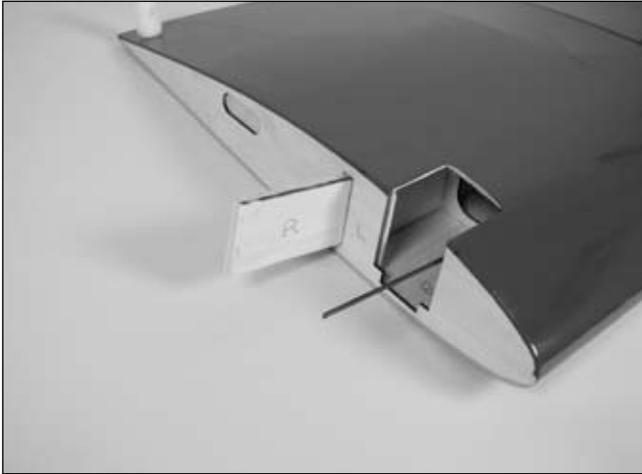

□ Step 3

Remove the covering in the leading edge for the wing dowels. Locate a $1/4" \times 1 \frac{3}{16}"$ (6mm x 30mm) wing dowel. Use 30-minute epoxy to glue the wing dowels into the center panel. The dowels should be inserted so $3/8"$ (9mm) of the dowel is left exposed in front of the leading edge. Repeat for both wing dowels.



□ Step 4

At this time you will need to know if you are installing flaps. The flap locking tab will not be able to be removed once it is installed. If the flaps on your Spitfire will be fixed, install the flap stay using two #4 x $1/2"$ sheet metal screws.



Note: If you later decide to install a servo to operate the flaps, the flap locking tab can be removed using a rotary tool and cut-off wheel.

□ Step 5

Without using any glue, test fit the wing panel and center panel together using the wing joiner. The panels must fit together without any gaps top or bottom. If gaps exist, use a sanding bar to lightly sand the root ribs of both panels until the panels fit together perfectly.

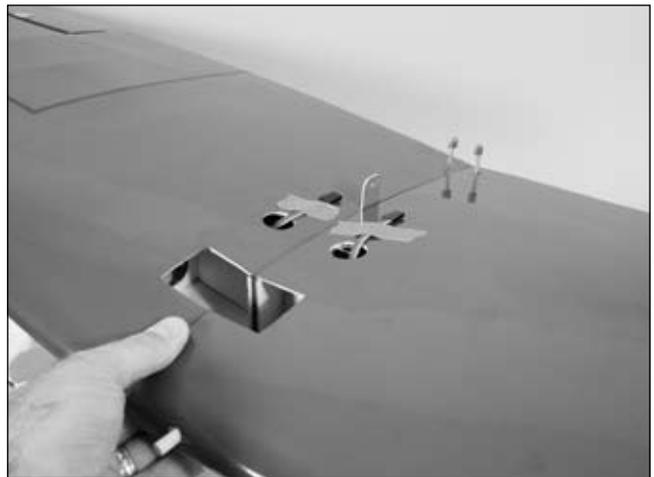

Note: Read through the remaining steps of this section before mixing any epoxy.

Section 2: Joining the Wing Panels

Hint: It is extremely important to use plenty of epoxy when joining the wing panels. It will also be helpful to use wax paper under the wing joint to avoid gluing the wing to your work surface.

□ Step 6

Mix approximately 1 ounce of 30-minute epoxy. Using an epoxy brush, apply a generous amount of epoxy to the wing joiner cavity of one of the wing panels.



□ Step 7

Completely coat half of the wing joiner with epoxy. Be sure to apply epoxy to the top and bottom of the joiner also. Insert the epoxy-coated side of the joiner into the wing joiner cavity up to the mark on the joiner. If you have used enough epoxy, it will ooze out of the cavity as the joiner is installed. Remove any excess epoxy using a paper towel and rubbing alcohol.

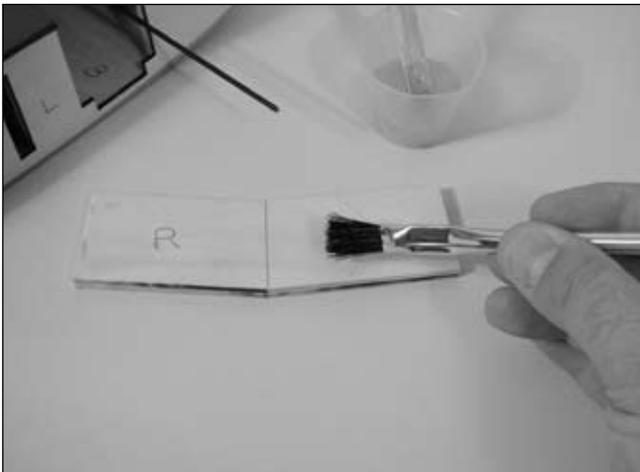

□ Step 8

Apply epoxy to the exposed portion of the wing joiner.

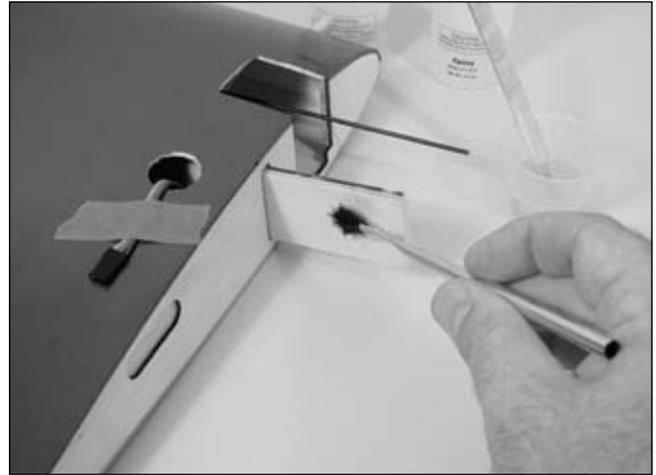

□ Step 9

Apply epoxy to root wing rib of both panels.



□ Step 10

Carefully slide the wing panels together. Apply enough pressure to firmly seat the two wing panels together, causing any excess epoxy to ooze out from between the panels. Use rubbing alcohol and a paper towel to remove the excess epoxy. Check to make sure there are no visible gaps between the panels.

Section 2: Joining the Wing Panels

□ Step 11

Use masking tape and rubber bands to securely hold the wing panels together. Allow the epoxy to fully cure before continuing to the next section.

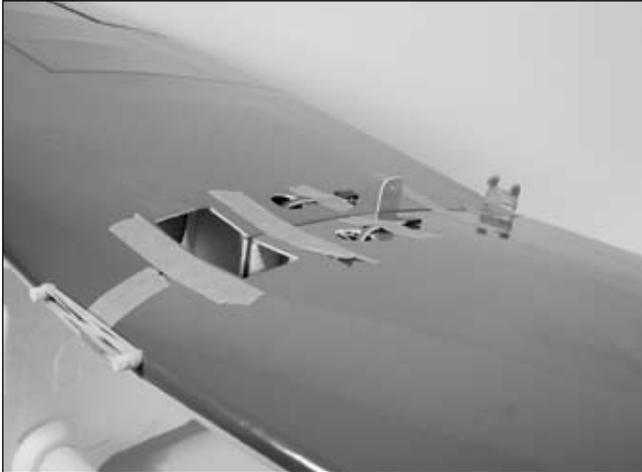

□ Step 12

Draw a centerline through the center of the bolts to aid in aligning the wing bolt plate in the next step.

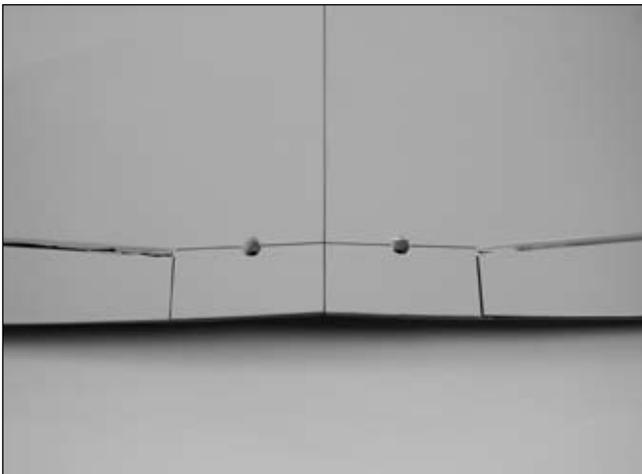

□ Step 13

Center the wing bolt plate on the wing using the line drawn in the last step. Trace the placement of the plate onto the wing using a felt-tipped pen.

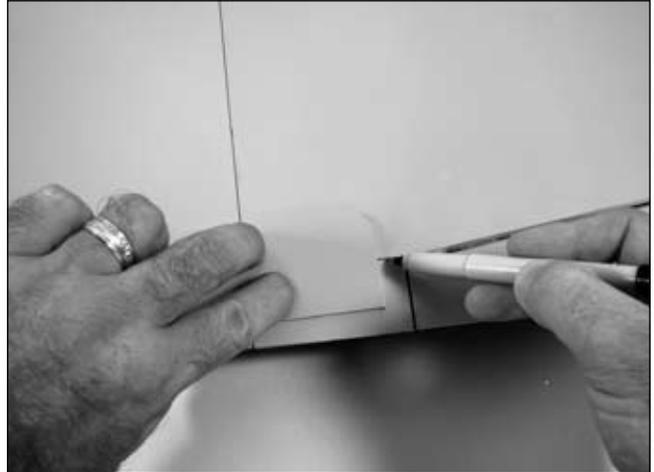

□ Step 14

Remove the covering 1/16" (1.5mm) inside the line drawn using a sharp hobby knife. Remove the lines from the wing using rubbing alcohol and a paper towel. Use medium CA to glue the plate in position.

□ Step 15

Use a 1/4" (6mm) drill bit and drill through the wing bolt plate for the wing bolts.



Section 3: Retract Installation

Required Parts

- Retract servo tray
- 3" main wheel (2)
- 5/32" wheel collar (4)
- 3mm setscrew (4)
- Quick connector washer (2)
- Quick connector (2)
- Quick connector retainer (2)
- 2mm wood screw (8)
- 3mm locknut (8)
- 3mm washer (8)
- Retract servo tray mount (2)
- Retract gear door (right and left)
- Gear door bracket (4)
- 3mm x 10mm machine screw (8)

Required Tools and Adhesives

- 6-minute epoxy
- Masking tape
- Retract Servo (JRPS703)
- Zap-A-Dap-A-Goo
- Hex wrench (included in kit)
- Drill
- Drill bit: 1/16" (1.5mm), 5/64" (2mm), 1/8" (3mm)

□ Step 1

Use 6-minute epoxy to glue the two retract servo tray mounts into the wing as shown. They will rest flush with the bottom wing sheeting on the inside of the wing.

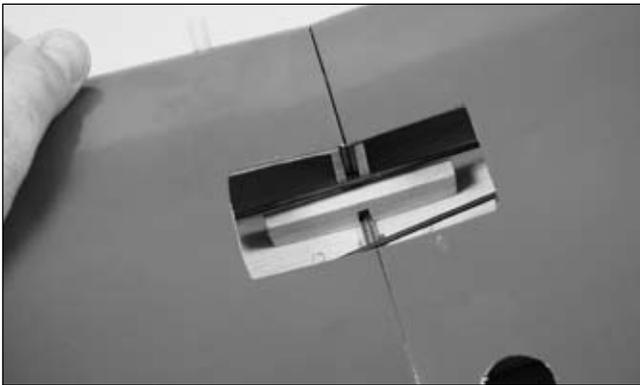

□ Step 2

Locate the retract servo tray. Use 6-minute epoxy to glue the servo tray into position.

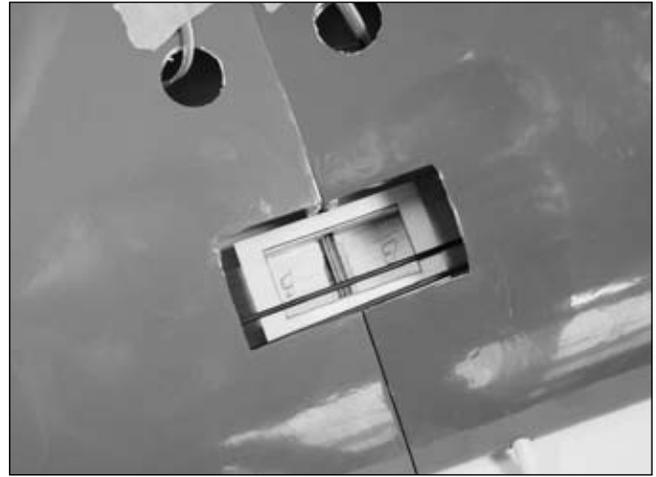

□ Step 3

Install a low-profile retract servo in the servo tray using the hardware provided with the servo. Prevent splitting the servo tray by drilling 1/16" (1.5mm) holes for the servo mounting screws.



Section 3: Retract Installation

□ Step 4

Select a servo arm from those included with your servo that has a distance of about 1" (25mm) between equally spaced holes as shown to start with. Use a 5/64" (2mm) drill bit to drill the appropriate holes in the arm.

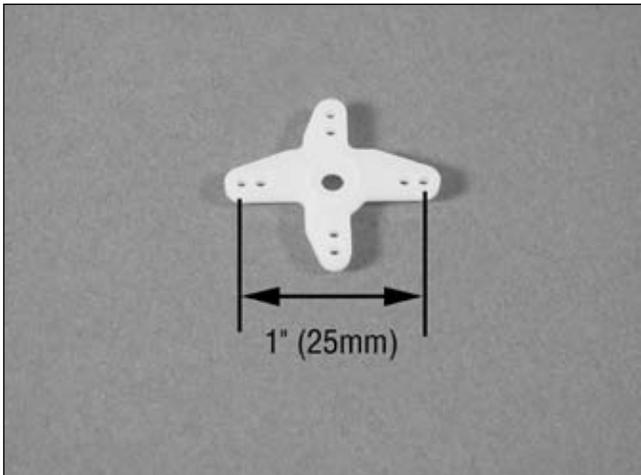

Note: The distance of 1" (25mm) may be different depending on the servo and radio system used. This measurement is simply used as a starting point.

□ Step 5

Attach two quick connectors to the servo arm using quick connector washers and retainers.



□ Step 6

Connect the retract servo to your radio system and electronically move the servo to the extended position. Slide the retract control wires through the quick connectors as shown and secure the servo arm to the retract servo.

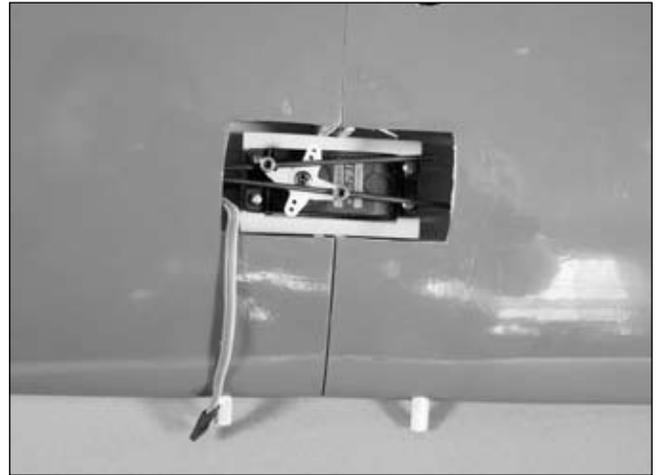

□ Step 7

With the retract servo in the extended position move the retract linkage to manually extend the landing gear. Install 3mm set screws into the quick connectors and tighten them to secure the retract linkage.

□ Step 8

Check the actuation of the retracts, making sure they lock in both the up and down positions. If you find the retracts binding when operated, reduce the distance between the connectors as described in Step 4 and 5. If they are not fully locking in either the up or down position, increase the distance between the connectors. Once complete, double-check all setscrews to make sure they are tight. A little threadlock may also be a good suggestion for these setscrews as well.

Remember: It may take some time to get the retracts adjusted so they lock properly in the up and down positions without binding.

Section 3: Retract Installation

□ □ Step 9

Attach the 3" main wheels to the retract struts using one 5/32" wheel collar, one washer and one 3mm setscrew. The washer is placed on the bent side of the strut, and the wheel collar is placed on the outside of the wheel.



Hint: If you want your wheels to stay on, there are two steps to help ensure that this will happen. One is to file a flat on the landing gear wire and tighten the setscrews onto the flat. The other is to use threadlock on the setscrews. Doing both will greatly reduce in-flight wheel loss.

□ □ Step 10

Place two of the gear door brackets onto the inside of the gear door as shown. Mark the location for the screws onto the gear door using a felt-tipped pen.

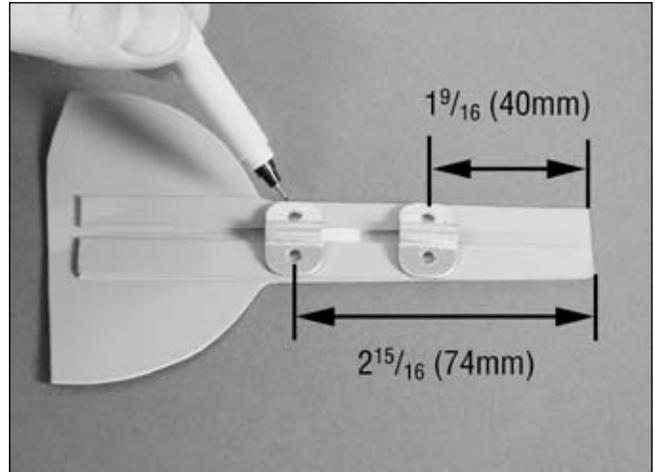

□ □ Step 11

Drill the location for the screws in the gear door using a drill and 1/8" (3mm) drill bit.

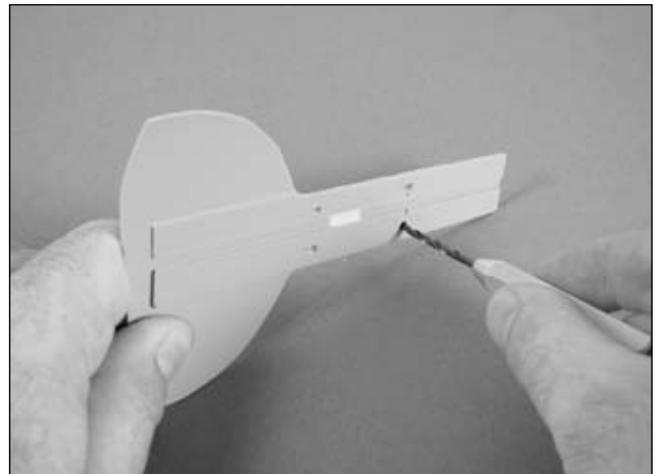

Section 3: Retract Installation

Step 12

Apply a thin bead of silicone adhesive to the gear door where it rests against the retract strut. Use four 3mm x 10mm machine screws, four 3mm locknuts and four 3mm washers, as well as the two gear door brackets, to secure the gear door to the retract strut.



Note: Retract the gear and position the gear door before the adhesive has had a chance to fully cure.

Note: If you notice that the retract has play when fully extended, it may be necessary to adjust the setscrew on the retract to eliminate this. The screw is located inside the retract, so it will have to be removed from the aircraft to make this adjustment.

Step 13

Repeat Steps 9 through 12 to complete the retract installation.

Section 4: Flap Installation

Required Parts

- Assembled wing
- Flap linkage
- CA hinge (6)

Required Tools and Adhesives

- Hinge glue
- 6-minute epoxy
- Felt-tipped pen

Step 1

Remove the flap from the wing. Roughen the flap linkage using medium grit sandpaper.



Step 2

Perform a trial run of installing the flap. There will be glue on the actuator and the hinges at the same time, so knowing how everything will fit together will help to prevent installing the flap incorrectly or having the glue cure before you have the flap fully in position.

Important: Do not use thin CA to glue the hinges in Step 3, as only one side of the hinge can be accessed. This may not provide enough adhesion between the hinge and surfaces. Your flaps may come off in flight if thin CA is used on only one side of the hinge.

Section 4: Flap Installation

□ Step 3

Apply a thin coat of hinge glue to one half of the three flap hinges. Slide the glued portion of the hinge into the flap.

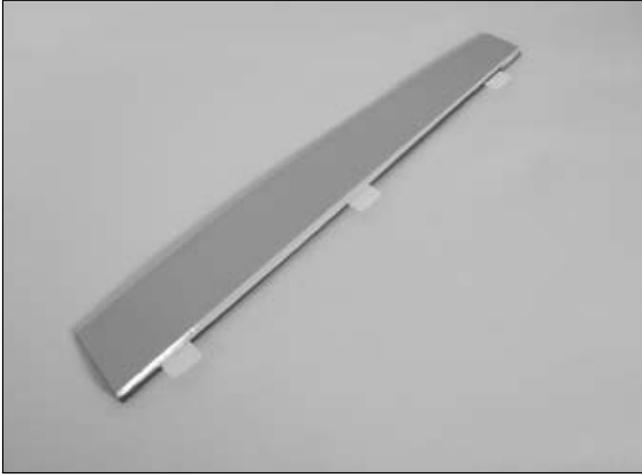

Note: It is always a good idea to follow the instructions provided by the manufacturer when using hinge glue.

□ Step 4

Slip a piece of plastic between the flap actuator and wing to prevent gluing the flap to the wing. Mix a small amount of epoxy and apply it to the actuator where it enters the flap, and to the hole in the flap where the linkage enters. Apply hinge glue to the three flap hinges. Slide the flap into position and allow the glue to fully cure before continuing.

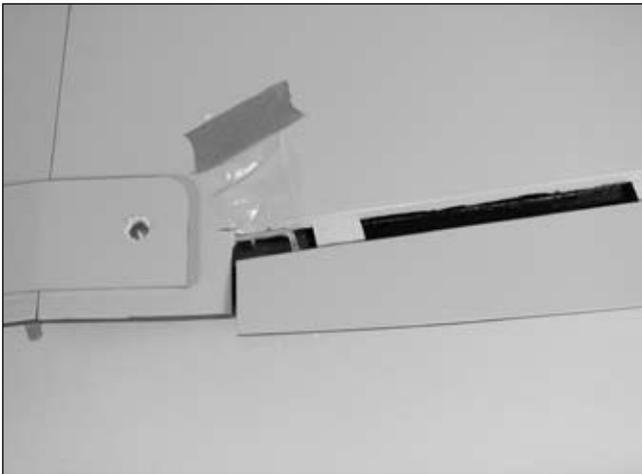

□ Step 5

Locate the flap linkage. Cut a 1/4" (6mm) piece of tubing for each of the two nylon clevises. Thread the clevises onto the flap linkage wire, then attach them to the flap control horns.

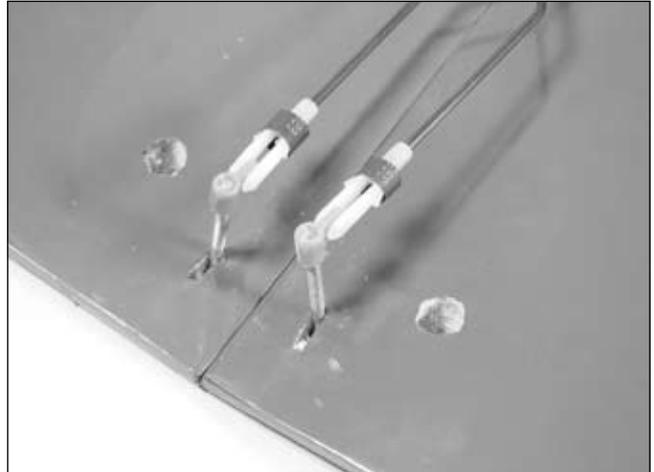

Note: Steps 6 and 7 cover the installation of the linkage for fixed flaps. If you are installing operational flaps, skip to Step 8.

□ Step 6

Pull the linkage toward the leading edge of the wing to raise the flaps. Mark the linkage with a felt-tipped pen where it crosses the hole in the flap linkage stay.

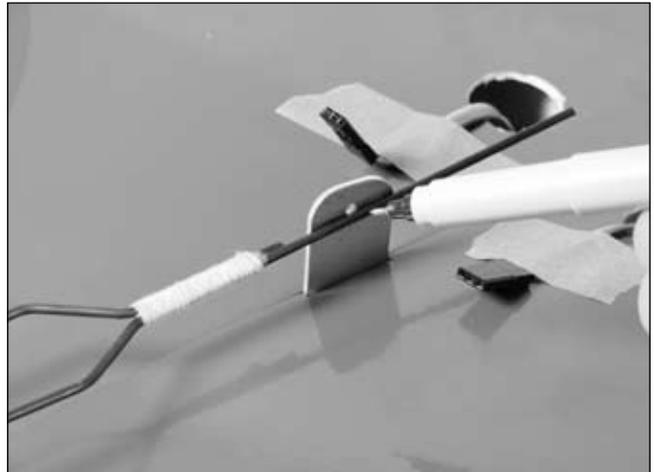

Section 4: Flap Installation

□ Step 7

Make a "Z" bend in the pushrod wire. Remove the clevises to slide the "Z" bend through the flap locking tab. Connect the clevises and check the position of the flaps. Thread the clevises in or out as necessary to position the flaps in the "UP" position.



□ Step 8

Use a hobby knife to remove the covering in the wing for the flap servo. Install the servo hardware, then mount the servo with the servo output facing the leading edge of the wing.

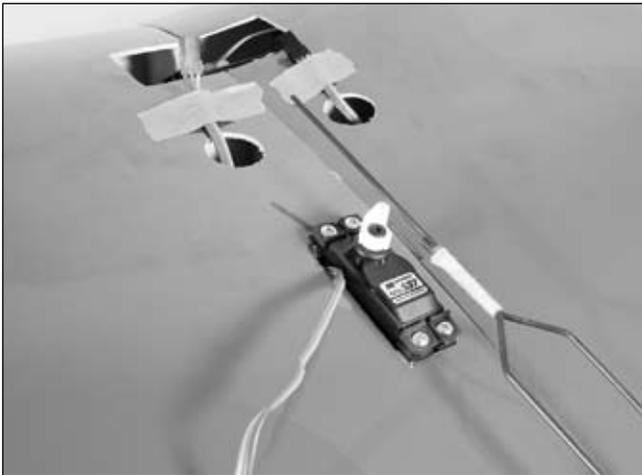

□ Step 9

Use the radio to check the operation of the flap servo. Install the control horn and move the servo to the "up" position. Install the servo horn. Move the flaps to the "up" position and use a felt-tipped pen to mark the linkage where it crosses the servo horn.

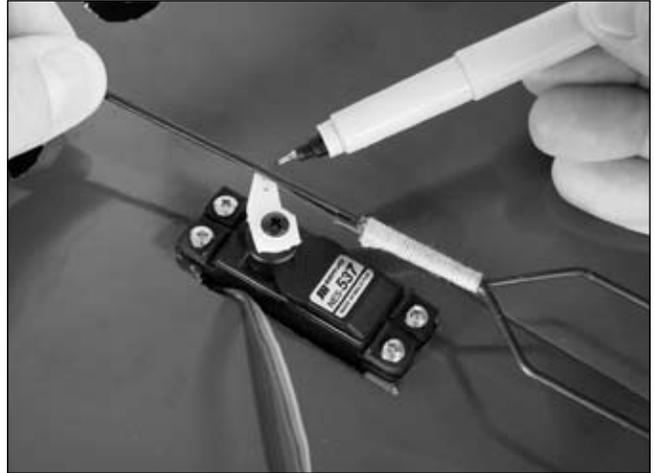

□ Step 10

Make a "Z" bend in the pushrod wire. Remove the servo horn to slide the "Z" bend through the horn. Secure the horn to the servo, then connect the clevises and check the operation of the flaps. Thread the clevises in or out as necessary to position the flaps equally.



Section 5: Engine Installation

Required Parts

- Fuselage
- Engine mount (2)
- 8-32 nylon lock nut (4)
- 8-32 blind nut (4)
- #8 washer (8)
- 2-56 x 18" pushrod
- 12" (300mm) throttle pushrod tube
- Assembled fuel tank
- Fuel tank support
- Pushrod connector w/ setscrew
- 8-32 x 3/4" socket head screw (4)
- 8-32 x 1 1/4" socket head screw (4)

Required Tools and Adhesives

- Hex wrench: 9/64"
- Ruler
- Socket wrench: 11/32"
- Engine
- Drill
- Drill bit: 5/32" (4mm)
- Felt-tipped pen
- Medium CA

□ Step 1

Position the engine on the mount and attach the engine using four 8-32 x 1 1/4" socket head screws, four #8 washers and four nylon lock nuts. Position the engine so the front of the drive washer is 5 1/2" (140mm) from the firewall. Also make sure the engine is perpendicular to your work surface by using a square. Tighten the bolts holding the engine once the engine is positioned.

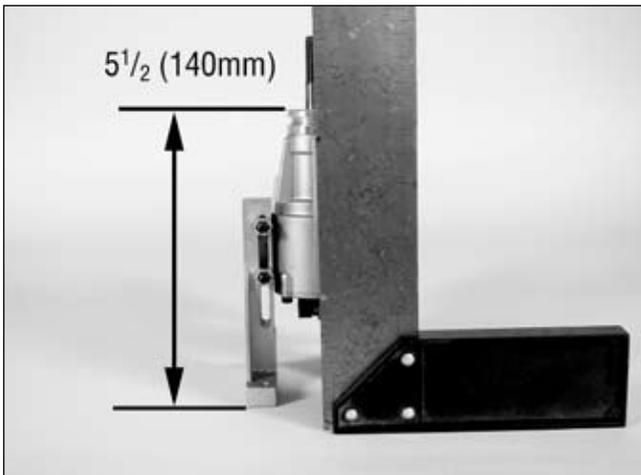

□ Step 2

Attach the engine to the fuselage using four 8-32 x 3/4" socket head screws, four #8 washers and four blind nuts. Center the engine mount in relationship to the oval holes in the firewall. Tighten the bolts holding the mount to the firewall. (Remember to make sure the barbs on the blind nuts go into the backside of the firewall.)



Note: It may be necessary to rotate the carburetor on your particular engine so the throttle arm is positioned as far as possible from the centerline of the fuselage.

□ Step 3

Determine the location for the throttle pushrod. Mark the location with a felt-tipped pen. Remove the engine and drill the firewall for the pushrod tube using a drill and 5/32" (4mm) drill bit.

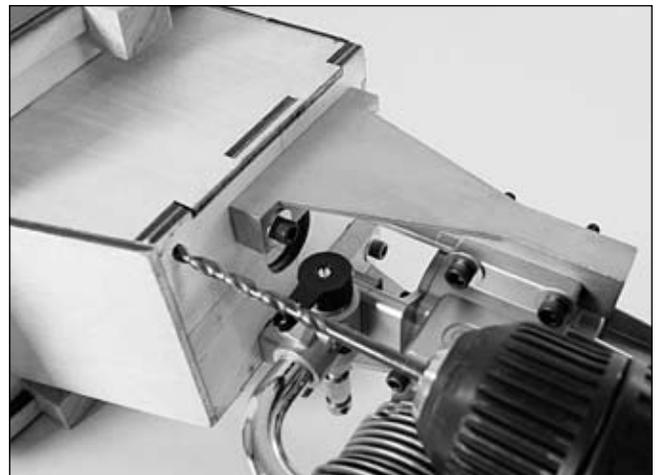

Section 5: Engine Installation

□ Step 4

Drill a 5/32" (4mm) hole in the former with the wing dowel holes that corresponds to the side of the hole drilled in the firewall. Make sure to drill so the pushrod won't interfere with the wing.



□ Step 5

Test fit the throttle pushrod tube through the firewall, through former 2, and into the fuselage. Once satisfied with the fit, roughen the tube using medium sandpaper. Slide the tube back into position and use medium CA to glue it to the firewall.

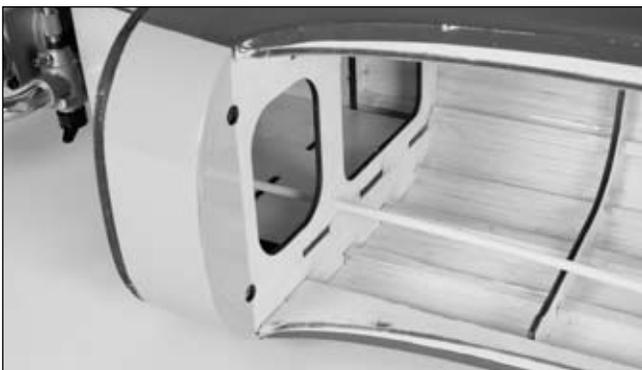
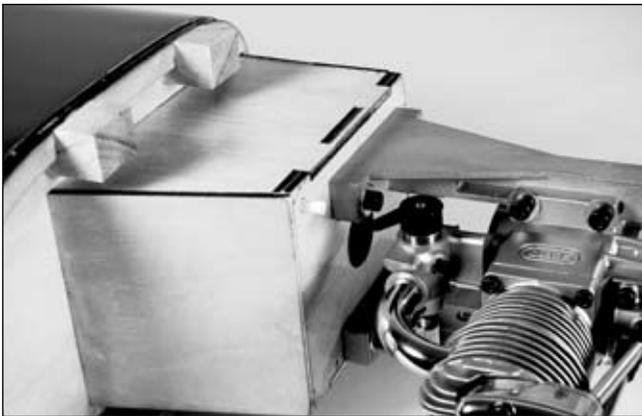

□ Step 6

Inspect the fuel tank to determine the direction of the vent tube inside the tank. Make sure the vent tube faces toward the top of the fuselage when installing the fuel tank into the fuselage. Install the fuel tank support to keep the tank from moving during flight using medium CA.



□ Step 7

Install the muffler onto your engine using the instructions provided by the manufacturer. Make the proper connections to the engine, using the engine manufacturer's instructions. If you are using a four-stroke, make sure to route the crankcase vent to the outside of the cowl.



Section 5: Engine Installation

□ Step 8

Attach a pushrod connector to the throttle servo arm. Install the throttle servo using the hardware provided with the servo. Electronically center the throttle servo using the transmitter and install the throttle arm as shown. Trim the pushrod tube around 1/4" (6mm) from former 2.



□ Step 9

Slide the pushrod wire into the tube. Attach the "Z" bend on the throttle pushrod wire onto the carburetor arm.



□ Step 10

Pass the throttle pushrod through the connector on the throttle servo arm. Bend the pushrod wire as necessary so it can move freely when operated by the servo.



□ Step 11

Use the radio system to move the throttle servo to the low position. Physically move the throttle linkage to close the carburetor. Tighten the setscrew in the connector to secure the linkage. Use the radio system to make sure the throttle can move freely from closed to fully open. Make any necessary adjustments to the linkage or to the radio to achieve full operation of the carburetor.

Section 6: Cowling Installation

Required Parts

- Fuselage assembly
- Cowling
- #4 x 5/8" sheet metal screw (4)

Required Tools and Adhesives

- Hobby scissors
- 6-minute epoxy
- Ruler
- Hobby knife
- Drill
- Drill bit: 1/8" (3mm), 3/32" (2.5mm)
- Phillips screwdriver (small)
- Rotary tool with sanding drum

□ Step 1

Remove the muffler from your particular engine. Slide the cowling onto the fuselage over the ending and note where the head of the engine contacts the cowl. Carefully remove small amounts of material until the cowling can fit over the head of the engine. Also remove material to attach the glow igniter.



Note: You can also use a remote glow igniter to avoid cutting a large hole in the cowling, providing a much cleaner installation of the cowl.

□ Step 2

Use a piece of card stock to indicate the location of the engine, needle valve, cowl mounting blocks and any other engine related items that will need to be accessed with the cowling on.

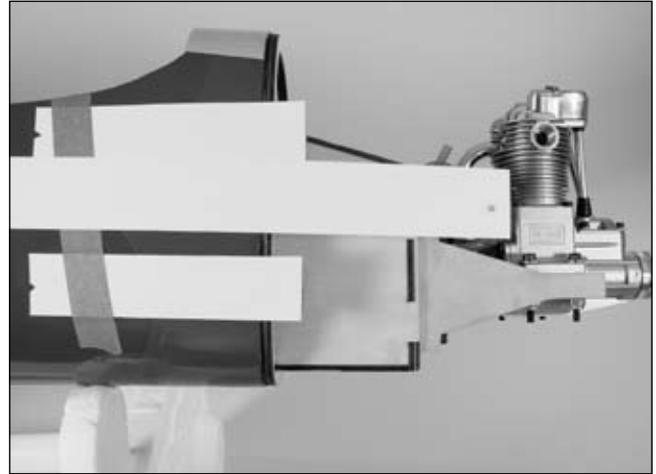

□ Step 3

Position the cowl onto the fuselage so the propeller drive washer extends beyond the cowl by roughly 1/8" (3mm). Transfer the locations indicated by the card stock onto the cowl.

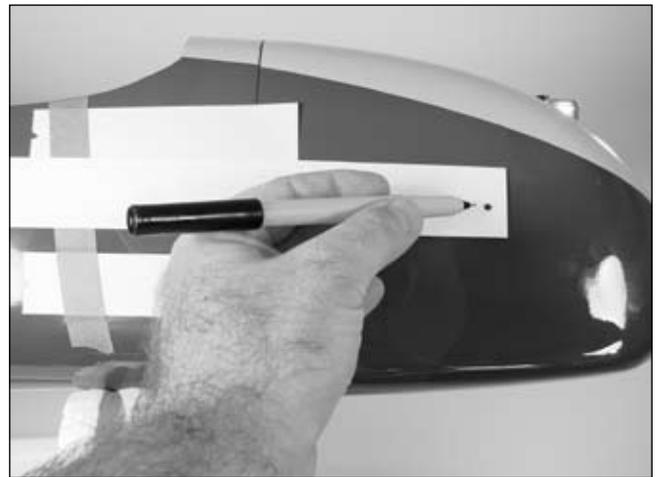

□ Step 4

Remove the cowl and remove material as necessary. Test fit the cowl over the engine to check the fit.

Note: Start by removing only a little material at a time. You can always make the holes bigger as you work. Work until the cowl fits nicely over the engine.

Section 6: Cowling Installation

□ Step 5

Slide the cowling onto the fuselage so it is tight against the fuselage. Also check that the drive washer is centered in the opening at the front of the cowl. Mark the position for the screws to secure the cowl to the cowl mounting blocks. Drill the locations using a 3/32" drill bit.

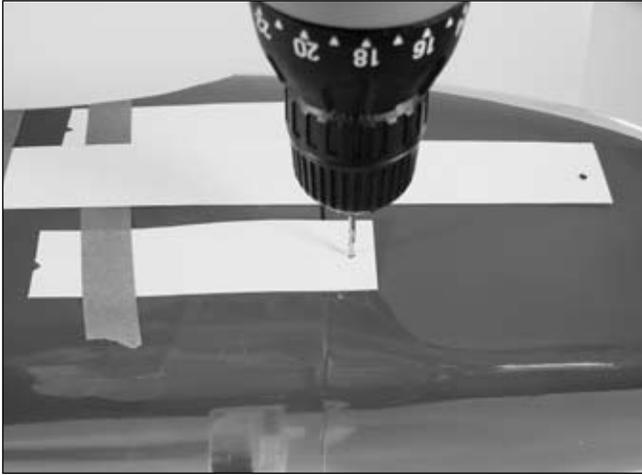

□ Step 6

Enlarge the holes drilled in the cowling using a 1/8" (3mm) drill bit.

□ Step 7

Attach the cowl using four #4 x 5/8" sheet metal screws. Apply a couple of drops of CA into the screw holes after threading the screws in a couple of times. This will harden the wood and keep the screws from loosening during flight.



□ Step 8

Attach the propeller and spinner to the engine. Check that the spinner can rotate without rubbing on the cowling, or isn't positioned with too much of a gap between it and the cowl. Reposition the engine on the mount if necessary for a perfect gap between the spinner and cowling.



□ Step 9

Glue the exhaust stacks to the cowling using 6-minute epoxy. Use masking tape to hold the exhaust in position until the epoxy fully cures.



Section 7: Rudder Installation

Required Parts

- Fuselage assembly
- Radio tray
- Tail wheel assembly
- #2 x 3/8" sheet metal screw (2)
- 29 1/2" (750mm) pushrod wire
- Heat shrink material
- Control horn w/backplate
- 2-56 x 9/16" machine screw (3)
- Rudder
- Nylon clevis

Required Tools and Adhesives

- 6-minute epoxy
- Drill
- T-pins
- Thin CA
- Drill bit: 1/8" (3mm)
- Hobby knife

□ Step 1

Use hobby knife to remove the covering from the bottom of the rudder to expose the hole and groove for the tail gear.

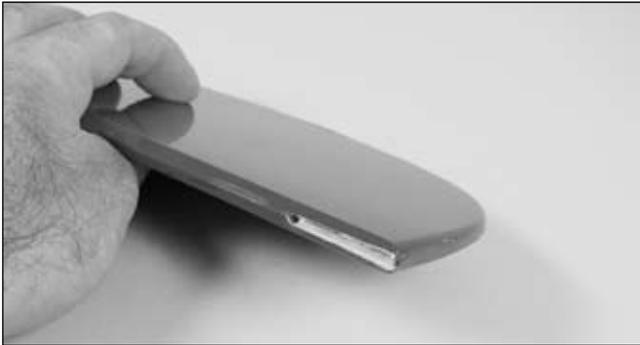

□ Step 2

Roughen the tail gear wire using medium grit sandpaper where it will enter the rudder. Use 6-minute epoxy to glue the wire into the rudder.

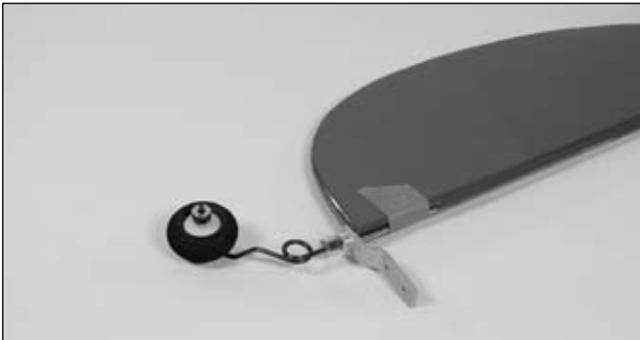

□ Step 3

Locate three CA hinges. Place a T-pin in the center of the hinges. Place the hinges into the rudder.

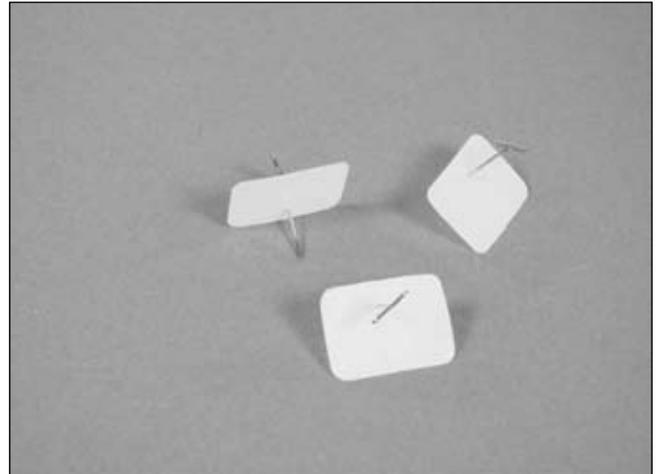

□ Step 4

Slide the hinges and rudder into position. Check that the gap between the rudder and fin is roughly 1/64" (.5mm). Apply thin CA to both sides of the hinges. Perform the pull test after the CA has fully cured.

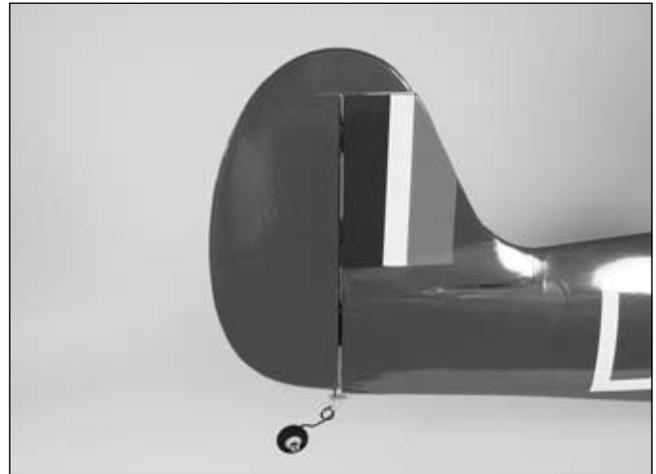

Section 7: Rudder Installation

□ Step 5

Secure the tail wheel bracket to the fuselage using two #2 x 3/8" sheet metal screws.



□ Step 6

Use 6-minute epoxy to glue the radio tray into the fuselage.



□ Step 7

Install the rudder servo using the hardware provided with the servo or radio system.

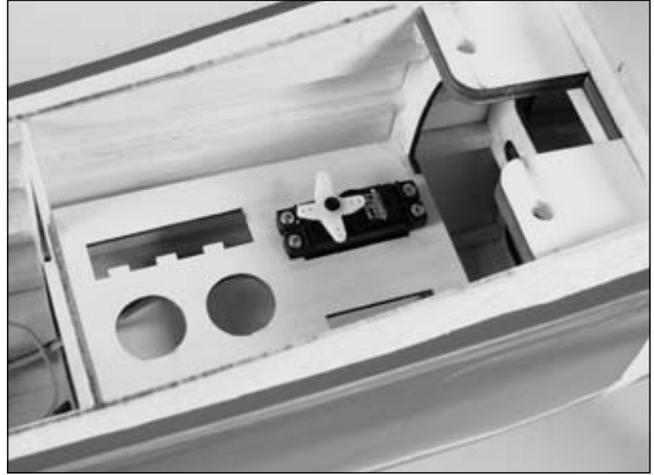

□ Step 8

Slide one of the 29 1/2" (750mm) pushrods into the rudder pushrod tube from the inside. Use a hobby knife to trim the covering from the fuselage where the pushrod exits. Cut a 1/4" (6mm) piece of heat shrink and place it over a nylon clevis. Thread the clevis onto the pushrod wire a minimum of 12 turns.



Section 7: Rudder Installation

□ Step 9

Remove the backplate from a control horn. Snap the clevis onto the horn and position the horn on the rudder. Use a felt-tipped pen to mark the location for the three mounting screws.



□ Step 10

Attach the control horn using the backplate and three 2-56 x 9/16" machine screws.



□ Step 11

With both the rudder servo and rudder centered, mark the rudder pushrod at the hole it crosses in the rudder servo arm using a felt-tipped pen.



□ Step 12

Enlarge the outer hole in the rudder servo arm using a 5/64" (2mm) drill bit. Bend the pushrod wire at the mark made in the last step. Pass the wire through the servo arm and secure it using a nylon wire keeper. Remove any unused arms from the servo horn.

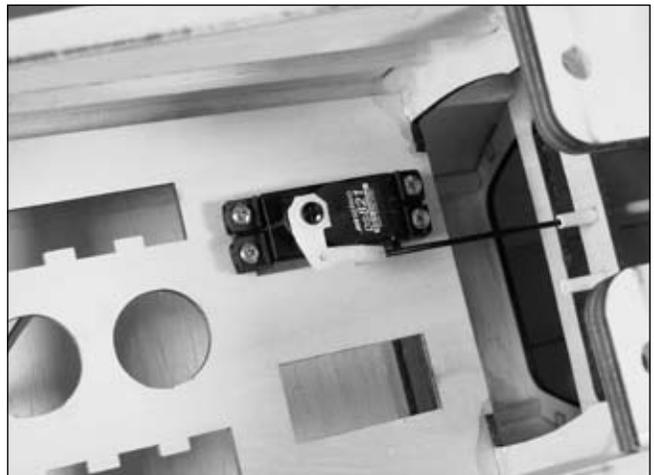

Section 8: Stabilizer Installation

Required Parts

- Assembled wing
- Stabilizer
- 1/4-20 blind nut (2)
- Elevator joiner wire
- 1/4-20 x 1 1/2" socket head bolt (2)
- Elevator (left and right)
- Fuselage
- Elevator joiner wire
- 1/4" washer (2)
- CA hinge (6)

Required Tools and Adhesives

- Hobby knife
- Ruler
- 30-minute epoxy
- Thin CA
- Drill
- Drill bit: 9/64" (3.5mm)
- Felt-tipped pen
- Sandpaper
- Pliers
- T-pins
- Hex wrench: 3/16"

□ Step 1

Use a sharp hobby knife to remove the covering from the slot in the rear of the fuselage for the stabilizer.



□ Step 2

Locate the two 1/4-20 blind nuts. Mix a small amount of 30-minute epoxy and apply it to the barbs of the blind nut. Use pliers or a C-clamp to install the blind nut from the inside of the fuselage.



Note: Make sure no epoxy gets into the threads of the blind nut.

Hint: A 1/4-20 bolt and large washer can be used to draw the blind nut into position as well.



Section 8: Stabilizer Installation

□ Step 3

Use the two 1/4 x 1 1/2" socket head bolts and 1/4" washers to attach the wing to the fuselage.

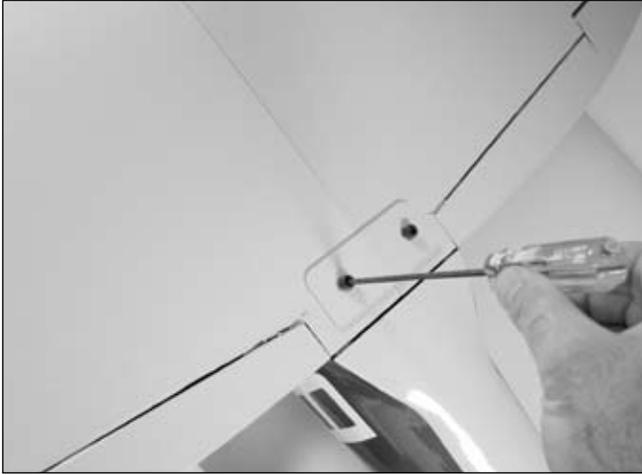

□ Step 4

Measure the distance between a point centered at the rear of the fuselage and each wing tip. The measurement will be equal if the wing is aligned correctly. If the measurement is not the same, slightly oval the hole for the wing bolts until an equal measurement is achieved.

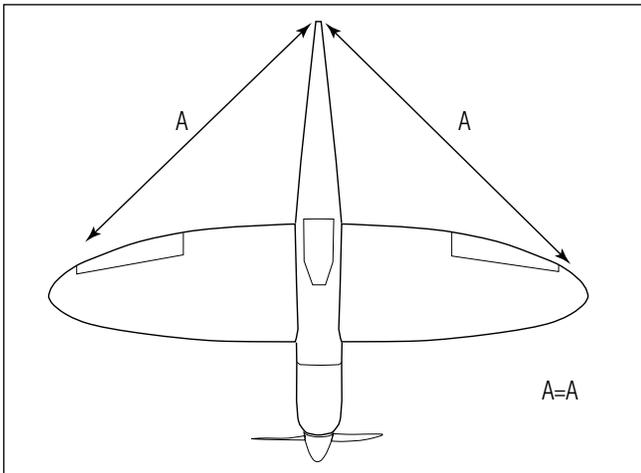

□ Step 5

Slide the stabilizer into the fuselage, making sure it is as far forward as possible. Center the stab in the opening by measuring the distance from the fuselage to each tip. The stab is aligned when both measurements are identical.

□ Step 6

Check the distance from each stab tip to each wing tip. These measurements must be equal for the stab to be aligned.

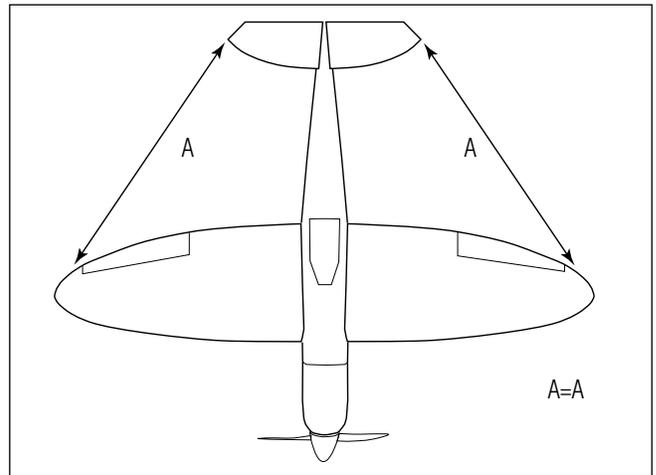

□ Step 7

Check to make sure the wing and stabilizer are parallel. If they are not, lightly sand the opening in the fuselage for the stab until the stab is parallel to the wing.

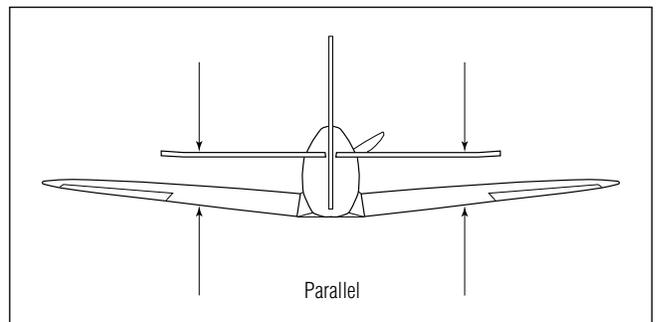

Section 8: Stabilizer Installation

□ Step 8

After verifying the alignment of the stabilizer, use a felt-tipped pen to trace the outline of the fuselage on the top and bottom of the stab.

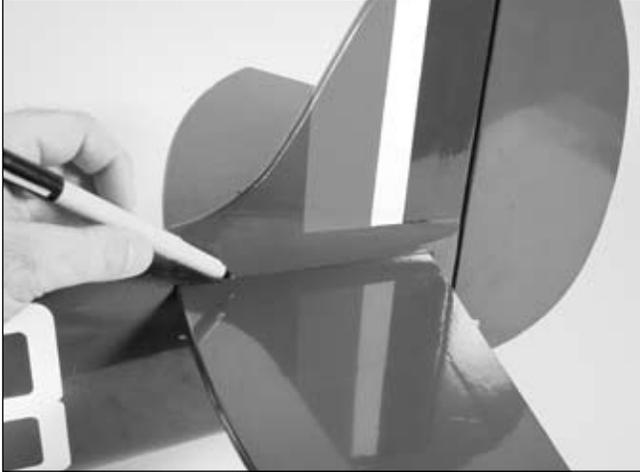

□ Step 9

Remove the stab and use a hobby knife with a new blade to remove the covering 1/16" (1.5mm) inside the lines just drawn. Use rubbing alcohol and a paper towel to remove the lines once they are no longer needed.



Note: Use care not to cut into the underlying wood and weaken the structure. Doing so could cause the stab to fail in flight, resulting in the loss of your airplane.

Hint: You can also use a soldering iron or hot knife to cut the covering. The heat will help melt the covering, rather than applying pressure and possibly cutting into the stabilizer.

□ Step 10

Slide the elevator joiner wire into the slot for the stabilizer. Slide the stabilizer partially back into the slot. Mix 1/2 ounce of 30-minute epoxy. Apply epoxy to the top and bottom of the exposed wood of the stabilizer. Slide the stabilizer the rest of the way into the slot in the fuselage. Double-check the alignment to verify it's correct. Remove any excess epoxy using a paper towel and rubbing alcohol. Allow the epoxy to fully cure before continuing.



Note: Continually check the alignment of the stabilizer while the epoxy cures.

Section 8: Stabilizer Installation

□ □ Step 11

Locate one of the elevator halves. Remove the covering from the slot in the elevator. Locate three CA hinges. Place a T-pin in the center of the hinges. Place the hinges into the elevator half.



□ □ Step 12

Test fit the elevator and stab together. The elevator joiner wire will be inserted into the hole drilled in the elevator.

□ □ Step 13

Lightly sand the joiner wire where it enters the elevator. Mix 1/2 ounce of 30-minute epoxy and apply it to the groove and hole in the elevator half. Insert the elevator joiner wire. Remove any excess epoxy using rubbing alcohol and a paper towel.

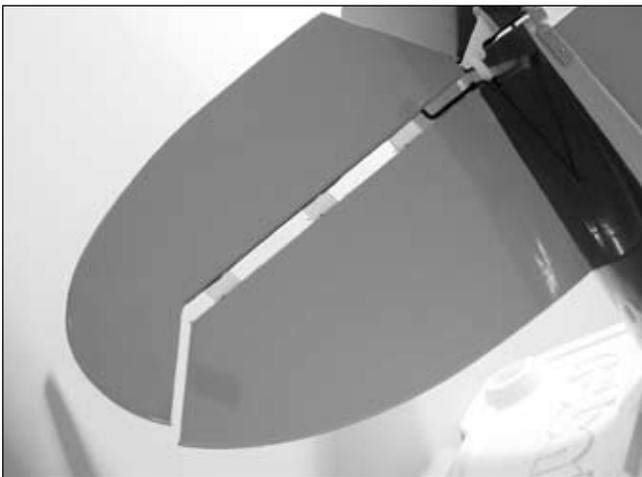

Note: You can combine the previous step with the following step if you like. This will hold the elevator in position while the epoxy cures.

□ □ Step 14

Check to make sure the elevator moves freely. Check to make sure the hinge gap between the elevator and stabilizer is roughly 1/64" (.5mm). Apply thin CA to both sides of the hinge. Make sure to saturate the hinge and don't use accelerator.

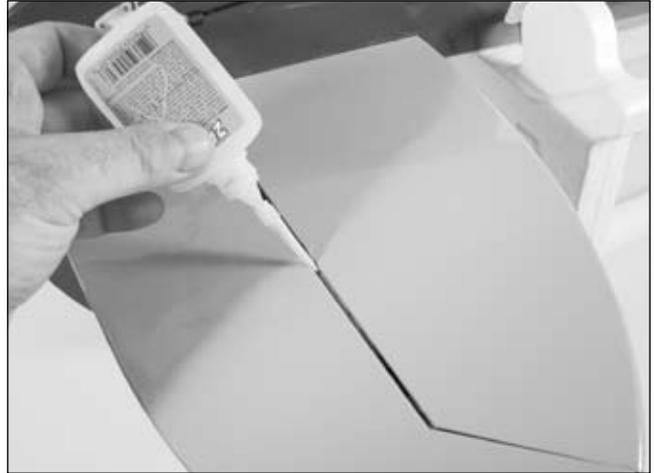

□ □ Step 15

Once the CA and epoxy have fully cured, gently pull on the elevator and stab to make sure the hinges are well glued. Flex the elevators a few times to break in the hinges.

□ Step 16

Repeat Steps 11 through 15 to install the remaining elevator half.



Section 8: Stabilizer Installation

□ Step 17

Install the elevator servo using the hardware provided with the servo or radio system.

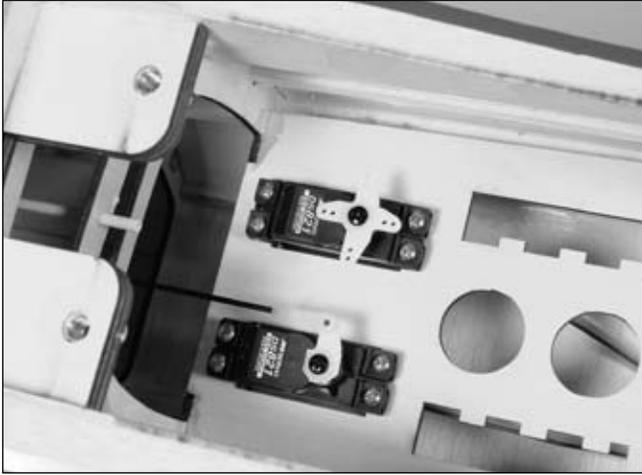

□ Step 18

Slide one of the 29 $\frac{1}{2}$ " (750mm) pushrods into the elevator pushrod tube from the inside. Use a hobby knife to trim the covering from the fuselage where the pushrod exits. Cut a 1/4" (6mm) piece of heat shrink and place it over a nylon clevis. Thread the clevis onto the pushrod wire a minimum of 12 turns. Remove the backplate from a control horn. Snap the clevis onto the horn and position the horn on the elevator. Use a felt-tipped pen to mark the location for the three mounting screws.



□ Step 19

Attach the control horn using the backplate and three 2-56 x 9/16" machine screws.

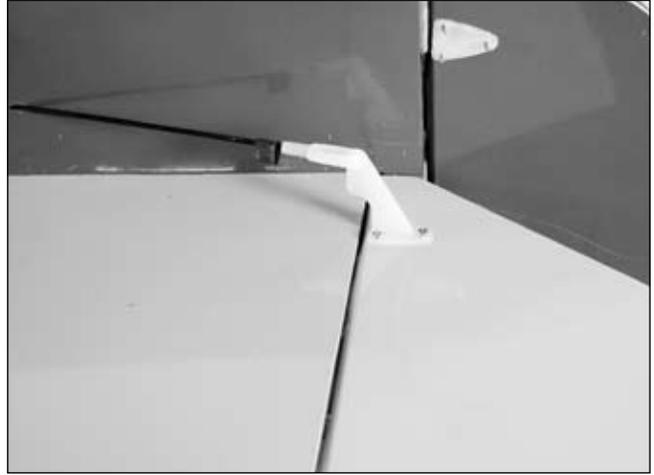

□ Step 20

With both the elevator servo and elevator centered, mark the elevator pushrod at the hole it crosses in the elevator servo arm using a felt-tipped pen. Enlarge the outer hole in the elevator servo arm using a 5/64" (2mm) drill bit. Bend the pushrod wire at the mark made in the last step. Pass the wire through the servo arm and secure it using a nylon wire keeper. Remove any unused arms from the servo horn.

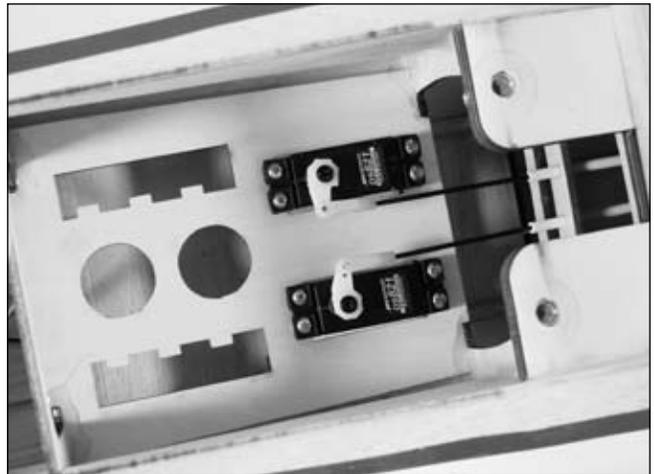

Section 9: Final Assembly

Required Parts

- Fuselage assembly
- Canopy
- Decal
- #2 x 1/2" sheet metal screw (2)

Required Tools and Adhesives

- Receiver
- Receiver battery
- Canopy glue (Formula 560)
- 1/4" (6mm) foam
- Sandpaper (medium grit)
- Hobby scissors
- Zap-A-Dap-A-Goo
- 6-minute epoxy

Step 1

Wrap the receiver and receiver battery in 1/4" (6mm) foam to prevent them from becoming damaged by engine vibrations.



Step 2

Plug the servos, switch harness and any necessary servo extensions into the receiver at this time.

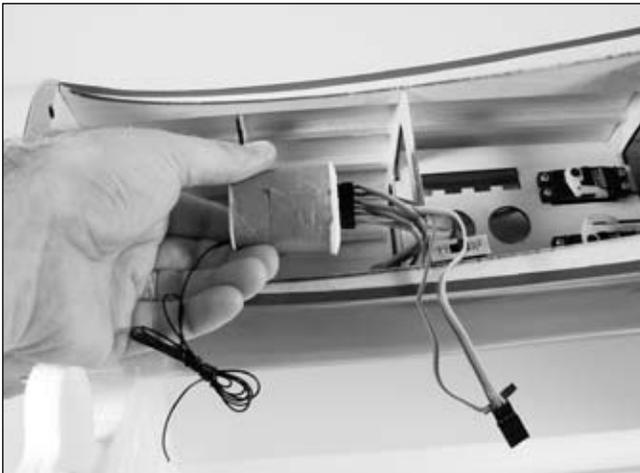

Step 3

Secure the receiver and receiver battery to the radio tray. Use hook and loop straps, tape, or rubber bands to hold them securely to the tray.



Step 4

Route the receiver antenna to the rear of the fuselage. Do not cut the antenna as this will greatly reduce the range of the radio system.

Step 5

Mount the switch harness to the side of the fuselage opposite that of the engine exhaust.



Step 6

Paint and install a pilot of your choosing. Use epoxy or Zap-A-Dap-A-Goo to secure the pilot.

Section 9: Final Assembly

Step 7

Use hobby scissors to trim the backrest. Use Zap-A-Dap-A-Goo to glue the backrest into position.



Step 8

Trim the instrument panel decal and apply it into position.

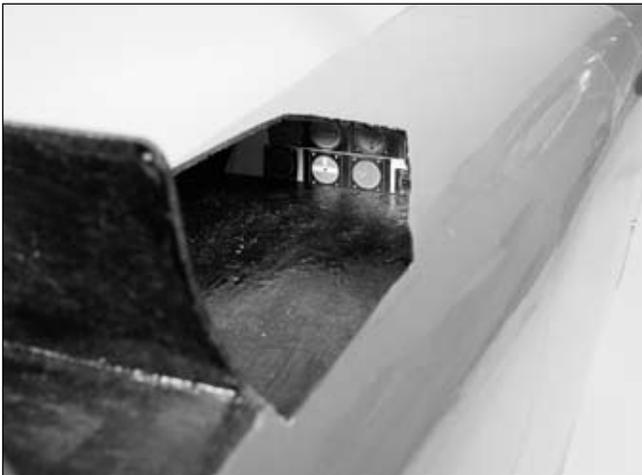

Step 9

Use Lexan scissors to trim the canopy.



Step 10

Position the canopy onto the fuselage. Trace around the canopy and onto the fuselage using a felt-tipped pen.



Step 11

Lightly sand the inside edge of the canopy and slightly inside the line drawn on the hatch using medium sandpaper.

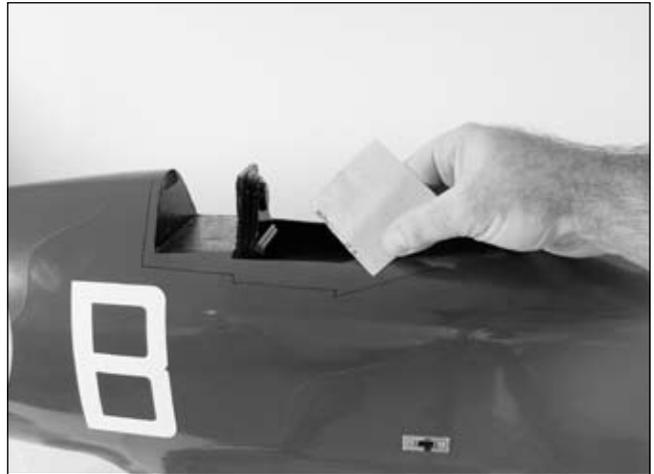

Section 9: Final Assembly

Step 12

Apply a bead of RCZ56 Canopy Glue (ZINJ5007) around the inside edge of the canopy. Position the canopy onto the hatch. Use tape to hold the canopy secure until the glue fully cures.



Step 13

Apply the decals. Use the photos on the box to aid in their location.

Step 14

Position the forward scoop on the wing and trace around it using a felt-tipped pen. Remove the covering 1/16" (1.5mm) inside the lines. Use canopy glue to secure the scoop to the wing.



Step 15

Use the same procedure to attach the radiators onto the bottom of the wing using canopy glue in the locations shown.



Step 16

The last detail is to install the antenna onto the fuselage. Use a hobby knife to cut a slot in the top of the fuselage for the antenna.

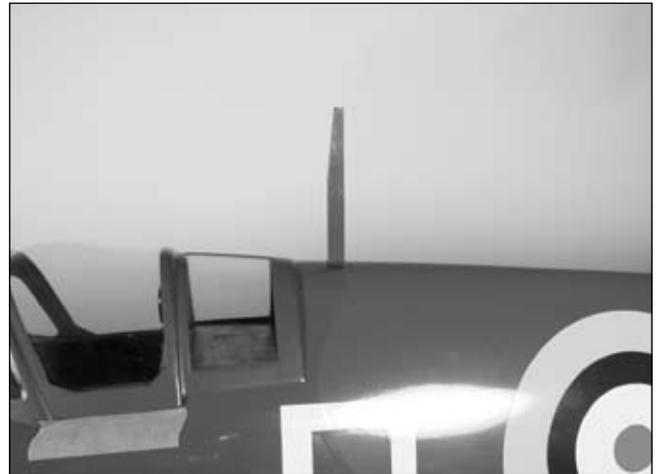

Adjusting the Engine

Step 1

Completely read the instructions included with your engine and follow the recommended break-in procedure.

Step 2

At the field, adjust the engine to a slightly rich setting at full throttle and adjust the idle and low-speed needle so that a consistent idle is achieved.

Step 3

Before you fly, be sure that your engine idles reliably, transitions and runs at all throttle settings. Only when this is achieved should any plane be considered ready for flight.

Control Throws

The amount of control throw should be adjusted as closely as possible using mechanical means, rather than making large changes electronically at the radio. By moving the position of the clevis at the control horn toward the outermost hole, you will decrease the amount of control throw of the control surface. Moving it toward the control surface will increase the amount of throw. Moving the pushrod wire at the servo arm will have the opposite effect: Moving it closer to center will decrease throw, and away from center will increase throw. Work with a combination of the two to achieve the closest or exact control throws listed.

Aileron

Low Rate: 1/2" (11°) up, 7/16" (10°) down

High Rate: 3/4" (16°) up, 11/16" (13°) down

Elevator

Low Rate: 1/2" (8°) up/down

High Rate: 1" (16°) up/down

Rudder

Low Rate: 1" (16°) left/right

High Rate: 1 1/4" (21°) left/right

Flap

Half Flap: 1/2" (15°)

Full Flap: 1" (30°)

Important: The linear measurements for the elevator and rudder are made at the widest part of the control surface. The linear measurement for aileron and flap throw is measured on the end where they meet; the inboard end of aileron and outboard end of flap.

Once the control throws have been set, use the supplied heat shrink tubing on each clevis to prevent them from opening during flight.



Recommended Center of Gravity (CG)

An important part of preparing the aircraft for flight is properly balancing the model. This is especially important when various engines are mounted.

Caution: Do not inadvertently skip this step!

The recommended Center of Gravity (CG) location for the Spitfire 60 is $5\frac{1}{4}$ " (133mm) behind the leading edge of the wing against the fuselage. Make sure the aircraft is inverted when measuring the CG. If necessary, move the battery pack or add weight to either the nose or the tail until the correct balance is achieved. Stick-on weights are available at your local hobby store and work well for this purpose.

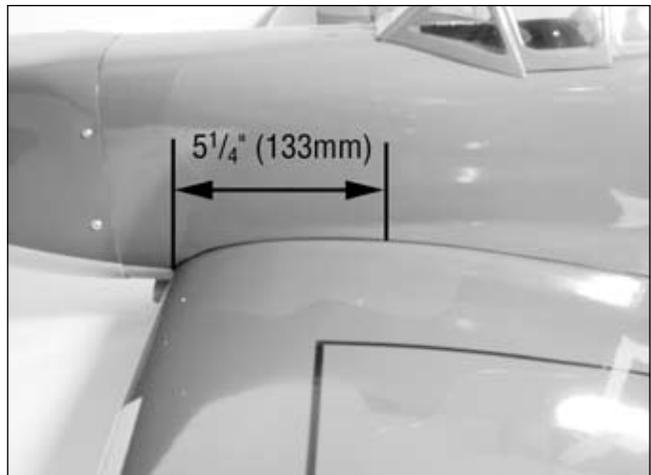

Pre-Flight

Charge both the transmitter and receiver pack for your airplane. Use the recommended charger supplied with your particular radio system, following the instructions provided with the radio. In most cases, the radio should be charged the night before going out flying.

Check the radio installation and make sure all the control surfaces are moving correctly (i.e. the correct direction and with the recommended throws). Test run the engine and make sure it transitions smoothly from idle to full throttle and back. Also ensure the engine is tuned according to the manufacturer's instructions, and it will run consistently and constantly at full throttle when adjusted.

Check all the control horns, servo horns and clevises to make sure they are secure and in good condition. Replace any items that would be considered questionable. Failure of any of these components in flight would mean the loss of your aircraft.

Range Test Your Radio

Range check your radio system before each flying session. This is accomplished by turning on your transmitter with the antenna collapsed. Turn on the radio in your airplane. With your airplane on the ground, you should be able to walk 30 paces away from your airplane and still have complete control of all functions. If not, don't attempt to fly! Have your radio equipment checked out by the manufacturer.

2006 Official AMA National Model Aircraft Safety Code

GENERAL

1) I will not fly my model aircraft in sanctioned events, air shows or model flying demonstrations until it has been proven to be airworthy by having been previously, successfully flight tested.

2) I will not fly my model higher than approximately 400 feet within 3 miles of an airport without notifying the airport operator. I will give right-of-way and avoid flying in the proximity of full-scale aircraft. Where necessary, an observer shall be utilized to supervise flying to avoid having models fly in the proximity of full-scale aircraft.

3) Where established, I will abide by the safety rules for the flying site I use, and I will not willfully and deliberately fly my models in a careless, reckless and/or dangerous manner.

4) The maximum takeoff weight of a model is 55 pounds, except models flown under Experimental Aircraft rules.

5) I will not fly my model unless it is identified with my name and address or AMA number, on or in the model. (This does not apply to models while being flown indoors.)

6) I will not operate models with metal-bladed propellers or with gaseous boosts, in which gases other than air enter their internal combustion engine(s); nor will I operate models with extremely hazardous fuels such as those containing tetranitromethane or hydrazine.

7) I will not operate models with pyrotechnics (any device that explodes, burns, or propels a projectile of any kind) including, but not limited to, rockets, explosive bombs dropped from models, smoke bombs, all explosive gases (such as hydrogen-filled balloons), or ground mounted devices launching a projectile. The only exceptions permitted are rockets flown in accordance with the National Model Rocketry Safety Code or those permanently attached (as per JATO use); also those items authorized for Air Show Team use as defined by AST Advisory Committee (document available from AMA HQ). In any case, models using rocket motors as a primary means of propulsion are limited to a maximum weight of 3.3 pounds and a G series motor. (A model aircraft is defined as an aircraft with or without engine, not able to carry a human being.)

8) I will not consume alcoholic beverages prior to, nor during, participation in any model operations.

9) Children under 6 years old are only allowed on the flight line as a pilot or while receiving flight instruction.

RADIO CONTROL

1) I will have completed a successful radio equipment ground range check before the first flight of a new or repaired model.

2) I will not fly my model aircraft in the presence of spectators until I become a qualified flier, unless assisted by an experienced helper.

3) At all flying sites a straight or curved line(s) must be established in front of which all flying takes place with the other side for spectators. Only personnel involved with flying the aircraft are allowed at or in the front of the flight line. Intentional flying behind the flight line is prohibited.

4) I will operate my model using only radio control frequencies currently allowed by the Federal Communications Commission. (Only properly licensed Amateurs are authorized to operate equipment on Amateur Band frequencies.)

2006 Official AMA National Model Aircraft Safety Code

- 5) Flying sites separated by three miles or more are considered safe from site-to site interference, even when both sites use the same frequencies. Any circumstances under three miles separation require a frequency management arrangement, which may be either an allocation of specific frequencies for each site or testing to determine that freedom from interference exists. Allocation plans or interference test reports shall be signed by the parties involved and provided to AMA Headquarters. Documents of agreement and reports may exist between (1) two or more AMA Chartered Clubs, (2) AMA clubs and individual AMA members not associated with AMA Clubs, or (3) two or more individual AMA members.
- 6) For Combat, distance between combat engagement line and spectator line will be 500 feet per cubic inch of engine displacement. (Example: .40 engine = 200 feet.); electric motors will be based on equivalent combustion engine size. Additional safety requirements will be per the RC Combat section of the current Competition Regulations.
- 7) At air shows or model flying demonstrations, a single straight line must be established, one side of which is for flying, with the other side for spectators.
- 8) With the exception of events flown under AMA Competition rules, after launch, except for pilots or helpers being used, no powered model may be flown closer than 25 feet to any person.
- 9) Under no circumstances may a pilot or other person touch a powered model in flight.

Organized RC Racing Event

- 10) An RC racing event, whether or not an AMA Rule Book event, is one in which model aircraft compete in flight over a prescribed course with the objective of finishing the course faster to determine the winner.
 - A. In every organized racing event in which contestants, callers and officials are on the course:
 1. All officials, callers and contestants must properly wear helmets, which are OSHA, DOT, ANSI, SNELL or NOCSAE approved or comparable standard while on the racecourse.
 2. All officials will be off the course except for the starter and their assistant.
 3. "On the course" is defined to mean any area beyond the pilot/staging area where actual flying takes place.
 - B. I will not fly my model aircraft in any organized racing event which does not comply with paragraph A above or which allows models over 20 pounds unless that competition event is AMA sanctioned.
 - C. Distance from the pylon to the nearest spectator (line) will be in accordance with the current Competition Regulations under the RC Pylon Racing section for the specific event pending two or three pylon course layout.
- 11) RC night flying is limited to low-performance models (less than 100 mph). The models must be equipped with a lighting system that clearly defines the aircraft's position in the air at all times.



© 2006 Horizon Hobby, Inc.
4105 Fieldstone Road
Champaign, Illinois 61822
(877) 504-0233
horizonhobby.com